

# CS Series Stepper Drive

The CS series is closed loop stepper drive designed to solve the loss of step problem in open loop stepper control systems, thus increase system reliability at minimal cost increase. It implements advanced control algorithm of Leadshine based on its tens of years' experience in stepper and servo controls. The CS series is highly reliable and affordable and performs excellent in many industrial applications such as CNC, medical, electronics, packaging...

The CS series can power 2-phase NEMA 17, 23, and 24 stepper motors with incremental encoders. Compared with traditional open loop stepper systems, the CS series adopted closed loop step system can eliminate potential loss of step, make real-time position error correction, and do not need torque reservation (100% torque implementation). Also it can power the driven stepper motor with reduced heating, lower noise, low vibration...

## Feature

- No loss of step
- No torque reservation
- No hunting or overshooting
- No tuning for easy setup
- Enhance performance at low speed application( 30-120 RPM)
- 20-50VDC supply voltage, max 7A output current
- Max 500 KHz input frequency
- Brake output does not need to connect a relay

## Model Designation

CS1 - D 50 7 - S

- 1 Series Name  
 CS : Closed loop stepper drive, without encoder Z signal output  
 CS1 : Closed loop stepper drive, with encoder Z signal output
- 2 Product Type  
 D: Drive
- 3 Max operatoin Voltage  
 50: 50VDC  
 72: 72VDC  
 100: 30-110VDC, or 18-80VAC
- 4 Output Current (Peak)  
 3: 3A  
 7: 7A  
 8: 8A
- 5 Remark  
 S: Normal type  
 E: Economic type

## Technical Specification

Name	CS1-D503S	CS1-D507S	CS1-D728S	CS-D507E	CS-D1008E
Command Source	PUL&DIR CW&CCW	PUL&DIR CW&CCW	PUL&DIR CW&CCW	PUL&DIR CW&CCW	PUL&DIR CW&CCW
Operation Voltage	20-50	20-50	20-72	20-50	18-80VAC 30-110VDC
Output Current (A, Peak)	3.0	7.0	8.0	7.0	8.0
Input Frequency (KHz, Max.)	500	500	500	500	500
Logical Voltage (VDC)	5 or 24	5 or 24	5 or 24	5 or 24	5 or 24

## Dimension

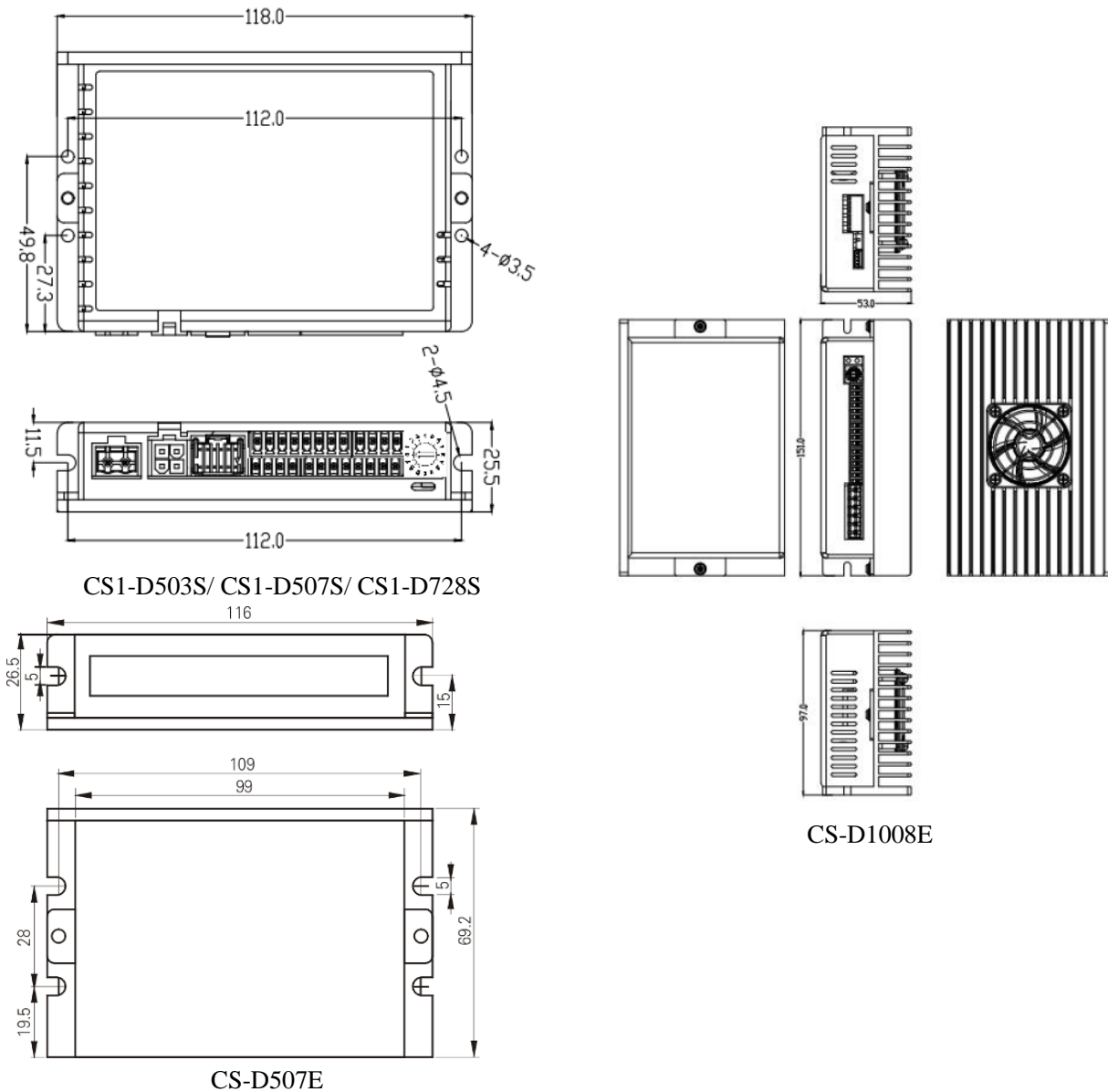

## Connector and Pin Assignment

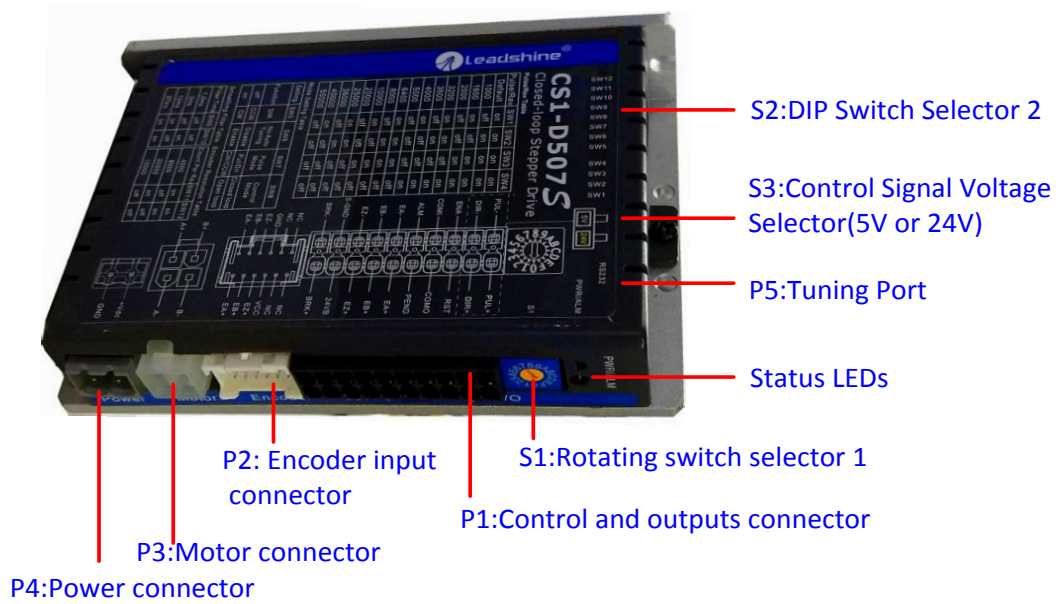

### ➤ P1 – Control and Digital Output Connections

The P1 connector in Figure 2 contains connections for control signals and a configurable digital output.

See the following table for details.

PIN	I/O	Details
PUL+ (CW+)	I	<u>Pulse and Direction Connection:</u> (1) Optically isolated, high level 3.5-5V or 24V, low voltage 0-0.5V
PUL- (CW-)	I	(2) Maximum 500 KHz input frequency
DIR+ (CCW+)	I	(4) Single pulse (step & direction) or double pulse (CW/CCW) is set by DIP Switch SW7
DIR- (CCW-)	I	(5) DIR signal requires advance PUL signal minimum 2 $\mu$ s in single pulse mode (6) The factory setting of control signal voltage is 24V, <b>must need</b> to set S3 (figure 2) if it is 5V
RST	I	<u>Alarm Reset and Enable Signals:</u> Optional. (1) RST means alarm reset, ENA means Enable. Optically isolated, single-ended. (2) RST and ENA: Effective high level is 3.5-24V; Effective low level is 0-0.5V connection
ENA	I	(3) RST signal can clear the alarm of “Position following error” and “Fail to lock motor shaft”, other alarms require the power supply to be restarted (4) ENA signal requires advance DIR signal minimum 2 $\mu$ s in single pulse mode, (default no connection)
COMI	I	Common connection of single-end input signals (common-cathode and common-anode)
COMO	O	Common connection of single-end output signals (common-cathode)
PEND	O	<u>In Position and Alarm :</u> They takes a sinking or sourcing 100mA current at 5-24V. Max 30V
ALM	O	
EAO+	O	Encoder A+ output

**Datasheet of CS Series Stepper Drive**

<b>EAO-</b>	<b>O</b>	Encoder A- output
<b>EBO+</b>	<b>O</b>	Encoder B+ output
<b>EBO-</b>	<b>O</b>	Encoder B- output
<b>EZO+</b>	<b>O</b>	Encoder Z +/- output, optional. Only if the closed-loop motor has Z signal input to CS1-D507S, the CS1-D507S will have Z signal output to controller or PLC
<b>EZO-</b>	<b>O</b>	
<b>24VB</b>	<b>I</b>	Used for brake signal, connect with +24 DC of external power supply, refer to <a href="#">chapter 7.2.3</a>
<b>BRK+</b>	<b>O</b>	Brake+ signal, Max. 24/500mA, connect with brake coil.
<b>BRK-</b>	<b>O</b>	Brake- signal, Max. 24/500mA, connect with brake coil. It's shown as SO7 in Leadshine ProTuner and level cannot be modified
<b>S-GND</b>	<b>O</b>	Signal GND

**Notes:** (1) Shielding control signal wires is suggested; (2) To avoid/reduce interference, don't tie control signal cables and power wires together; (3) Brake output does not need to connect a relay

**➤ P2 - Encoder Signal Input Connector**

The P2 connector in Figure 2 is for encoder signal connection. Refer to the following table for details.

<b>Drive Pin Name</b>	<b>Description</b>
<b>NC</b>	No connection
<b>VCC</b>	+5V voltage for encoder
<b>GND</b>	Power ground connection
<b>EZ+</b>	Encoder Z+ input connection
<b>EZ-</b>	Encoder Z- input connection
<b>EB+</b>	Encoder B+ input connection
<b>EB-</b>	Encoder B- input connection
<b>EA+</b>	Encoder A+ input connection
<b>EA-</b>	Encoder A- input connection

**➤ P3 - Motor Connector**

<b>PIN</b>	<b>Details</b>
A+	Connect to motor A+ wire
A-	Connect to motor A- wire
B+	Connect to motor B+ wire
B-	Connect to motor B- wire

**➤ P4 - Power Connector**

<b>Pin</b>	<b>Details</b>
GND	Connect to power supply ground connection.
+VDC	Connect to power supply positive connection. Suggest 24-48VDC power supply voltage

**Warning:** Don't plug/unplug P3 or P4 connector to avoid drive damage or injury while powered on.

## Datasheet of CS Series Stepper Drive

### ➤ P5 - Tuning Port

CS1 series has a tuning port with RS232 to modify the drive parameters, it's only for tuning, not for equipment control because neither precision nor stability is sufficient. If you need a field bus drive, use a Leadshine RS485 or EtherCAT type drives:

<http://www.leadshine.com/ProductSubType.aspx?type=products&category=stepper-products&producttype=stepper-drives&subtype=network-stepper-drives>

The interface definition is as follows:

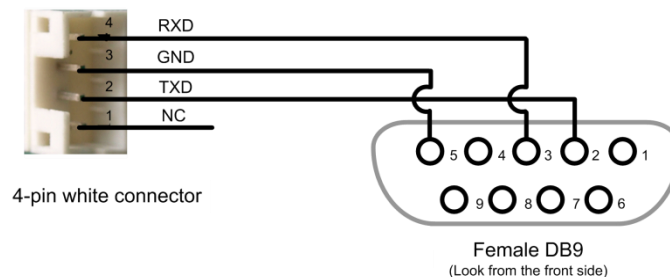

The CS1 series has one rotating switch, one 12-bit DIP switch and one 1-bit selector switch. “Default” means that parameters can be modified by Leadshine PC software, “Factory” means that factory setting, suitable for most customer applications

### ➤ S1 - Rotating Switch Configurations

This rotating switch is used to set the peak current of the drive and motion gain, from the motor phase current and application requirements. When the rotating switch code is set to 8, the user can modify the drive peak current value and Kp & Ki value through Leadshine PC software.

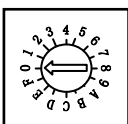
	Peak Current	Code	Velocity loop Ki	Position loop Kp	Velocity loop Kp	Remark
	4.0A	0	0	25	25	1) Recommended motors are CS-M22306 and CS-M22313;
		1	0	50	15	2) Velocity loop Ki Indicates the stop time and position accuracy , “0” indicates the stop time is long, but the position error is smaller. “16” means the stop time is short, but the position error is slightly larger.
		2	0	75	10	
		3	0	100	5	
		4	16	25	25	3) Position loop Kp and velocity loop Kp is a pair of composite parameters that represent rigidity. “25” and “25” composite parameters indicate the rigidity is weak, “100” and “5” composite parameters indicate the rigidity is strong.
		5	16	50	15	
		6	16	75	10	
		7	16	100	5	4) Usually keep factory settings
	6.0A	8(default & factory)	0	25	25	1) Recommended motors are CS-M22323, CS-M22326, CS-M22331-L, CS-M22422 and CS-M22430;
		9	0	50	15	2) Velocity loop Ki Indicates the stop time and position accuracy , “0” indicates the stop time is long, but the position error is smaller. “16” means the stop time is short, but the position error is slightly larger.
		A	0	75	10	
		B	0	100	5	
		C	16	25	25	3) Position loop Kp and velocity loop Kp is a

**Datasheet of CS Series Stepper Drive**

	D	16	50	15	pair of composite parameters that represent rigidity. “25” and “25” composite parameters indicate the rigidity is weak, “100” and “5” composite parameters indicate the rigidity is strong. 4) Usually keep factory settings
	E	16	75	10	
	F	16	100	5	

**➤ S2 - DIP Switch Configurations**

The 12-bit is located on the side (DIP switch S2 in Figure 2) and used to configure settings of micro step resolution, output current, and motor standstill current as shown below, the factory setting of SW1-SW12 is **ON, OFF, OFF, ON, OFF, OFF, ON, OFF, OFF, OFF, OFF, OFF**.

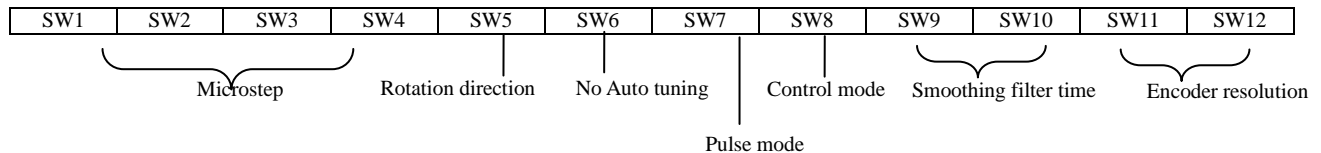
**● Micro Step (SW1-SW4)**

Each CS1-D507S has 8 micro step settings which can be configured through DIP switch SW1, SW2, SW3 and SW4. See the following table for detail. When they are set to **ON, ON, ON, ON**, the microstep can be set via Leadshine PC software.

Micro step	Pulses/Rev. (for 1.8° motor)	SW1	SW2	SW3	SW4
2	400 (default)	ON	ON	ON	ON
5	1000	OFF	ON	ON	ON
8	1600	ON	OFF	ON	ON
10	2000	OFF	OFF	ON	ON
16	3200	ON	ON	OFF	ON
18	3600	OFF	ON	OFF	ON
20	4000 (factory)	ON	OFF	OFF	ON
25	5000	OFF	OFF	OFF	ON
32	6400	ON	ON	ON	OFF
40	8000	OFF	ON	ON	OFF
50	10000	ON	OFF	ON	OFF
100	20000	OFF	OFF	ON	OFF
125	25000	ON	ON	OFF	OFF
180	36000	OFF	ON	OFF	OFF
200	40000	ON	OFF	OFF	OFF
250	50000	OFF	OFF	OFF	OFF

**● Mode Setting (SW5 - SW8)**

Function	ON	OFF

<b>SW5</b>	Rotation Direction	CW (clockwise)	CCW (counterclockwise)
<b>SW6</b>	No Auto Tuning	Enable	Disable
<b>SW7</b>	Pulse Mode	CW/CCW (double pulse)	PUL/DIR (single pulse)
<b>SW8</b>	Control Mode	Open loop control	Closed loop control

● **Smoothing Filter Time Configuration (SW9-SW10)**

CS1-D507S has an advanced feature called control command smoothing to make the input pulse from pulse generator (controller, PLC, etc.) S-curve acceleration, to improve motion smoothness and high-speed start frequency in many circumstances.

This is achieved through adding filtering time which is configured SW9-SW10. See the following table for how to configure. When SW9-SW10 setting is OFF, OFF, the filtering time can be set by Leadshine PC software.

Filter Time	SW9	SW10
1.5 ms (default and factory)	OFF	OFF
3 ms	OFF	ON
12 ms	ON	OFF
37 ms	ON	ON

Note: The Filter Time value must be set to the same for each CS1-D507S in multi-axis applications

● **Encoder Resolution Configuration (SW11-SW12)**

CS1-D507S can power closed loop stepper motors with incremental encoders (include and under 5000 ppr resolution ) , it has 2-bit DIP switch to set motor encoder resolution as below, When SW11-SW12 setting is ON, ON, the encoder resolution can be set by Leadshine PC software.

Encoder Resolution (ppr)	Count per Rev. (cpr)	SW11	SW12
1000	4000 (default)	ON	ON
2000	8000	OFF	ON
5000	20000	ON	OFF
2500	10000 (factory)	OFF	OFF

➤ **S3 - Selector Switch Configurations**

The 1-bit selector is located on the top (S3 in figure 2), used to configure the voltage of control signals. For the safety of optically coupled, the factory setting is 24V, which no need to connect 2K resistors, making it easier to use. When the voltage of the control signal is 5V, the S3 must be set to 5V, otherwise, the motor won't work.

# Wiring

