

NO	DESCRIPTION	SPECIFICATION	MAT'L	Q'TY	REMARK

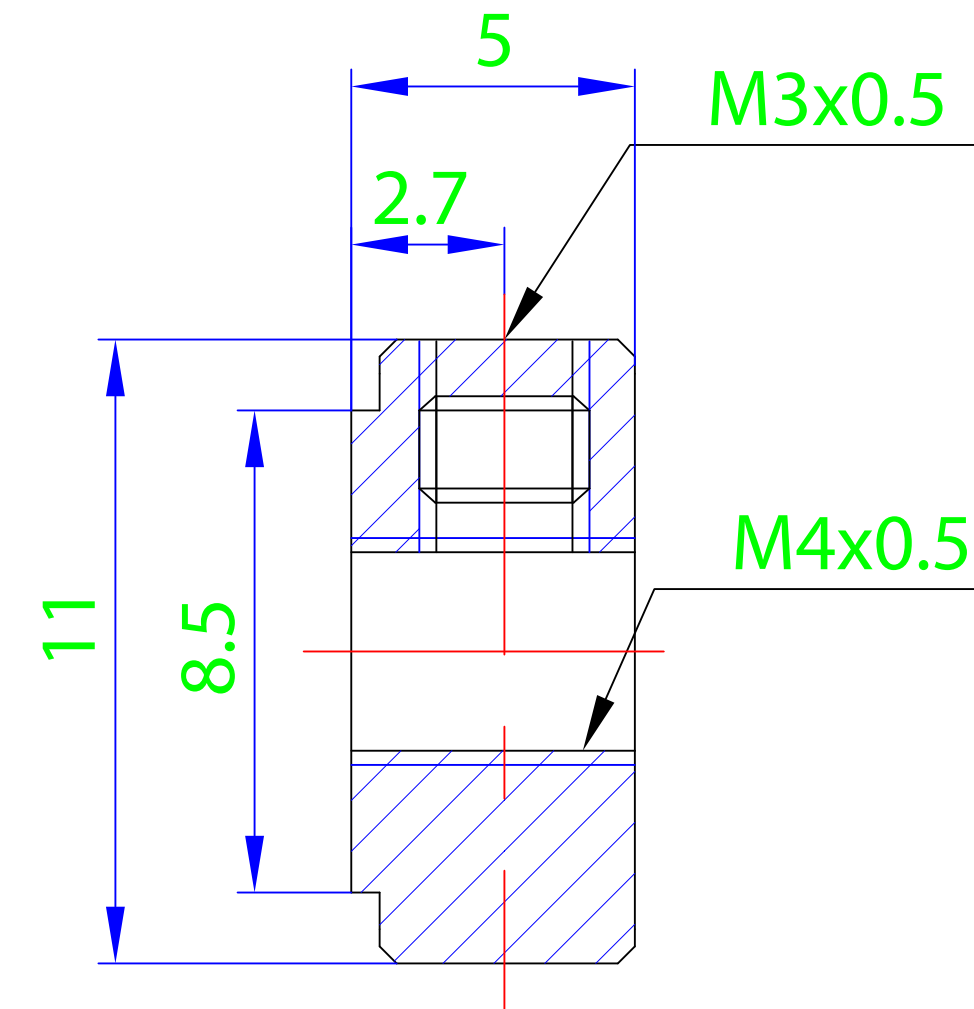
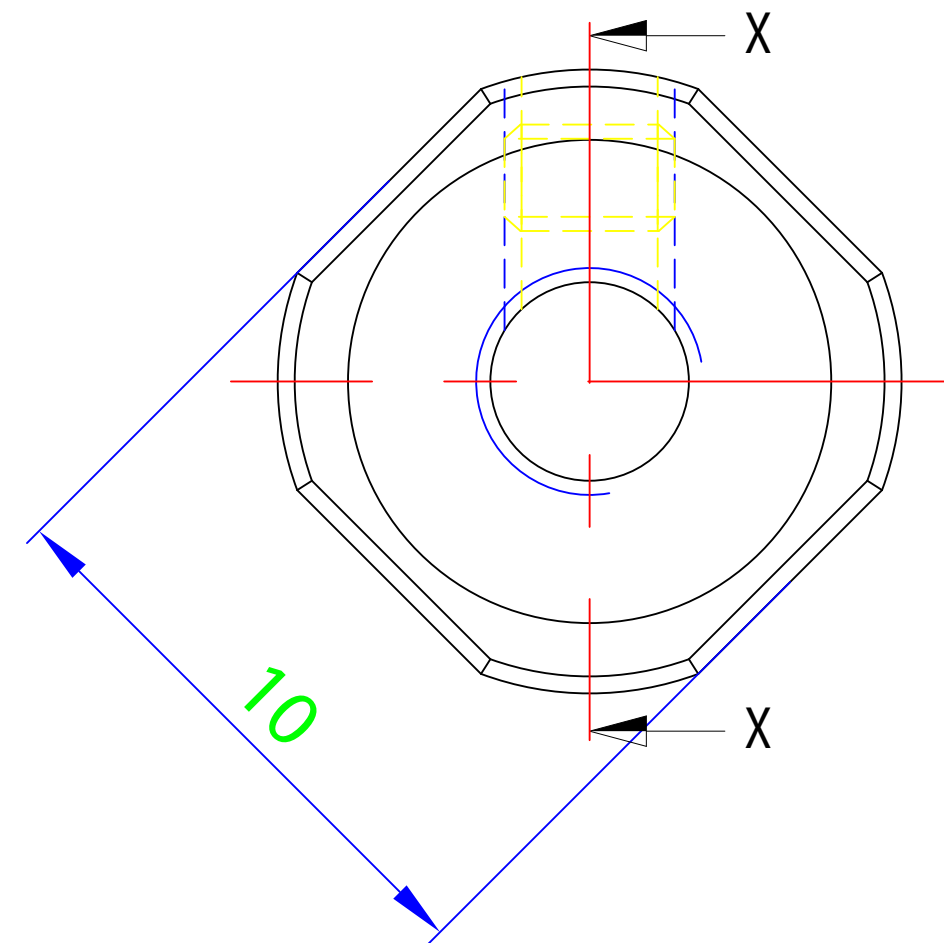
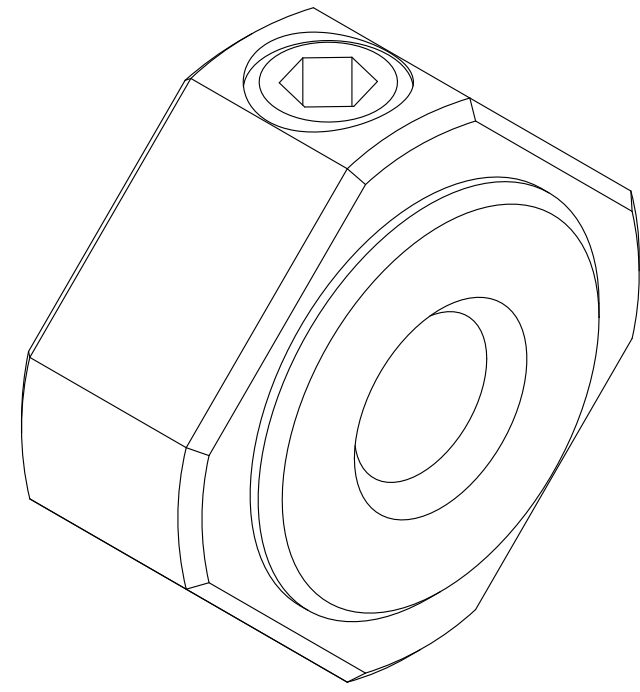

Section X-X

MARK	REASON OF REVISIONS	REVISIONER	CHECKER	DATE

REVISION

가공치수허용차		
범위	정밀급	보통급
0.5 ~ 6까지	±0.05	±0.1
6 ~ 30까지	±0.1	±0.2
30 ~ 120까지	±0.15	±0.3
120 ~ 315까지	±0.2	±0.5
315 ~ 1000까지	±0.3	±0.8
1000 ~ 2000까지	±0.5	±1.2
지시없는 모따기 및 라운드	R = 0.2~0.3	C = 0.2~0.3

APPROVED BY	
CHECKED BY	
DRAWN BY	



TITLE			
RN4 외관도			
SIZE	Dwg.NO. RN4-0000		
A	SCALE	1:1	DATE

NO	DESCRIPTION	SPECIFICATION	MAT'L	Q'TY	REMARK

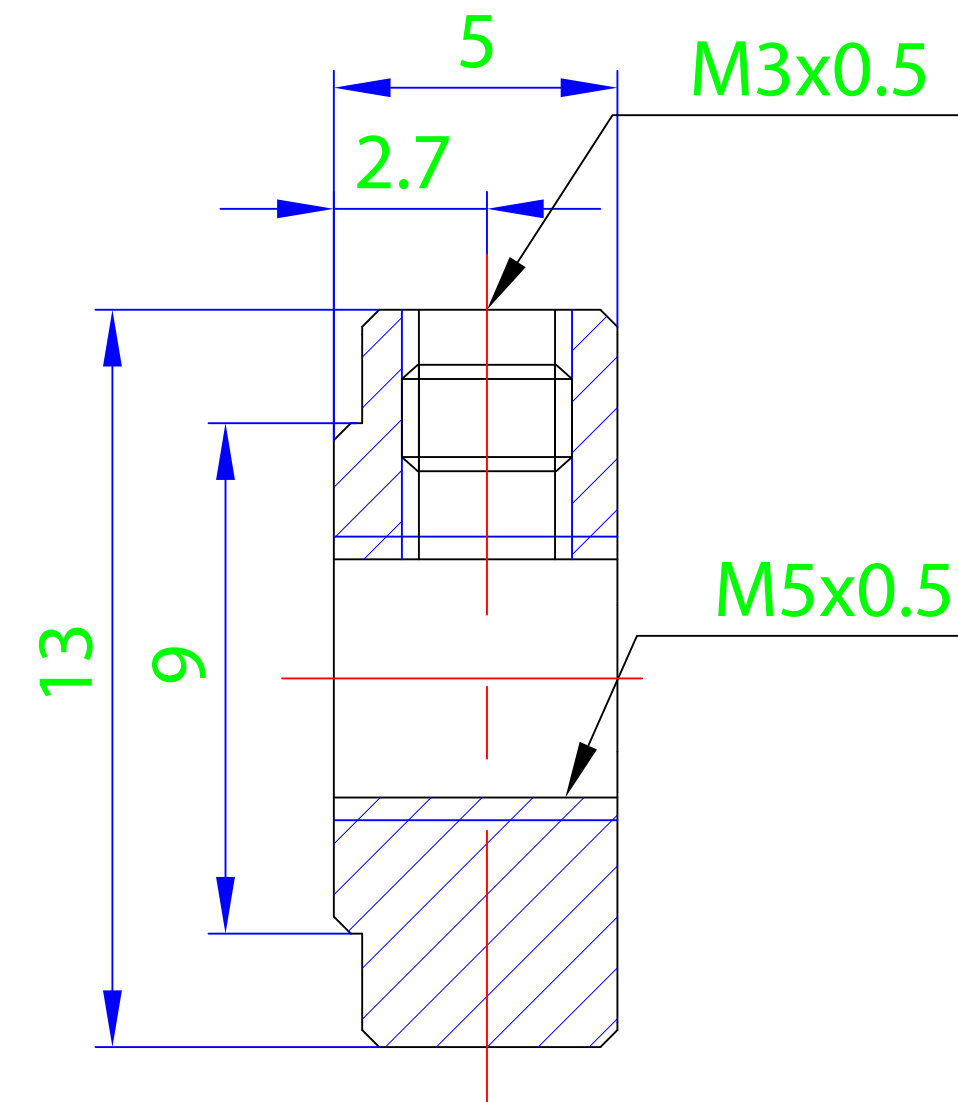
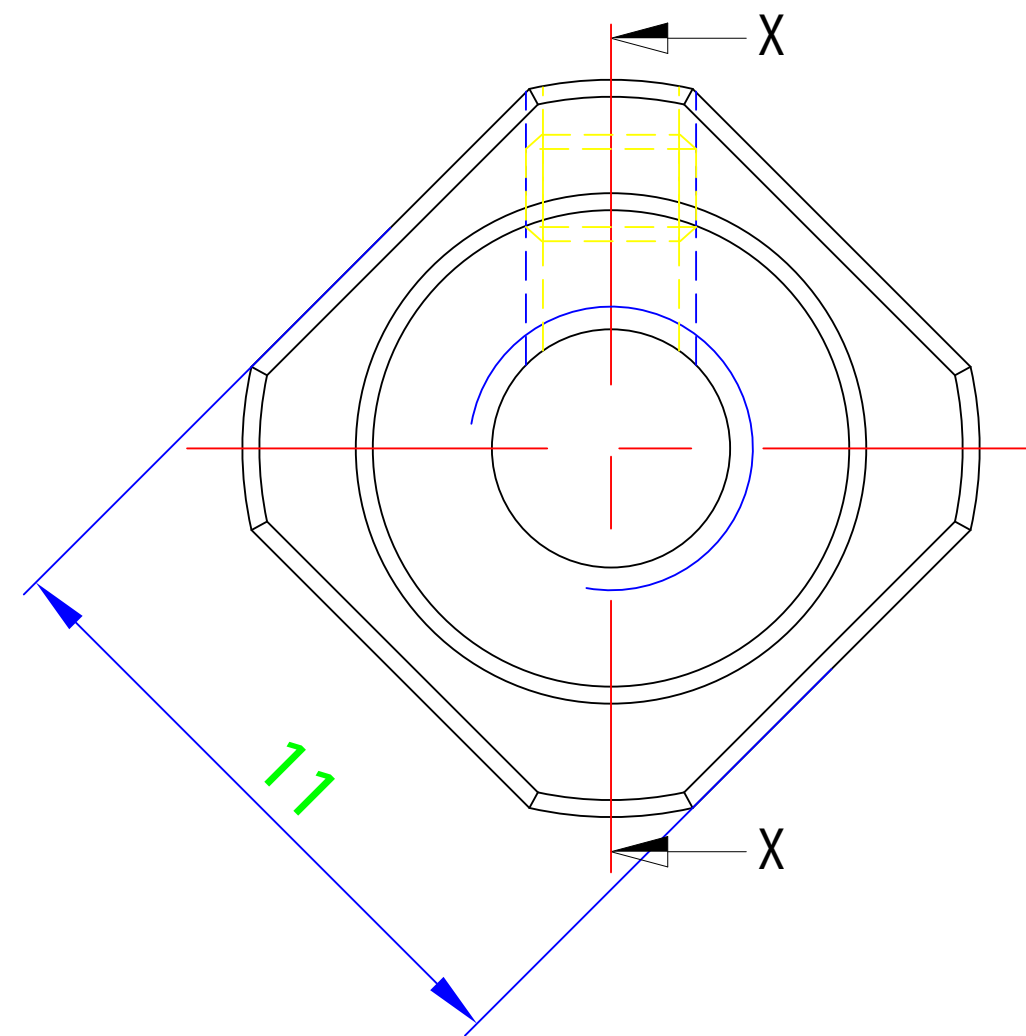
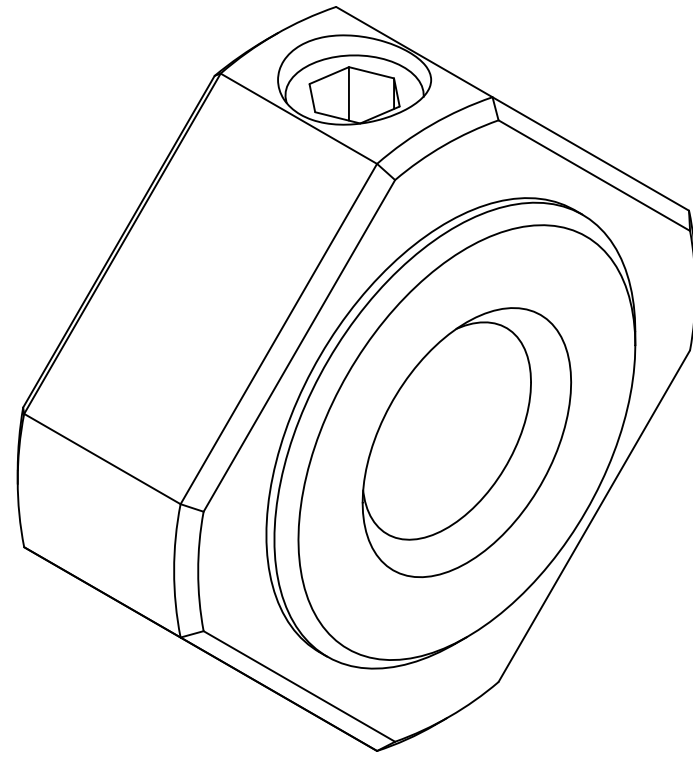

Section X-X

MARK	REASON OF REVISIONS	REVISIONER	CHECKER	DATE

HEAT TREAT

가공치수허용차		
범위	정밀급	보통급
0.5 ~ 6까지	±0.05	±0.1
6 ~ 30까지	±0.1	±0.2
30 ~ 120까지	±0.15	±0.3
120 ~ 315까지	±0.2	±0.5
315 ~ 1000까지	±0.3	±0.8
1000 ~ 2000까지	±0.5	±1.2
지시없는 모따기 및 라운드	R = 0.2~0.3	C = 0.2~0.3

APPROVED BY
CHECKED BY
DRAWN BY

TITLE			
RN5 외관도			
SIZE	Dwg.NO. RN5-0000		
A	SCALE	1:1	DATE

NO	DESCRIPTION	SPECIFICATION	MAT'L	Q'TY	REMARK

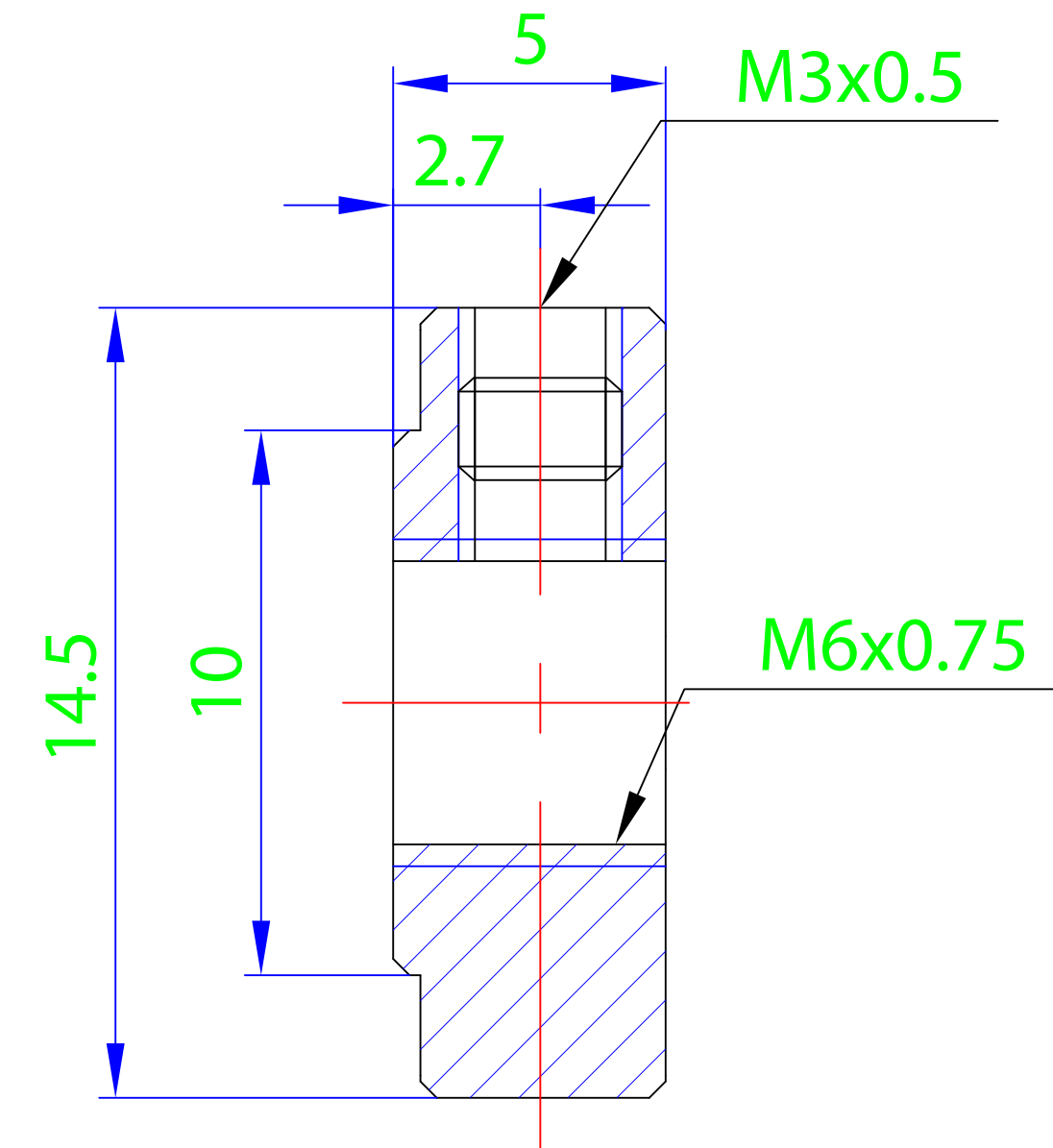
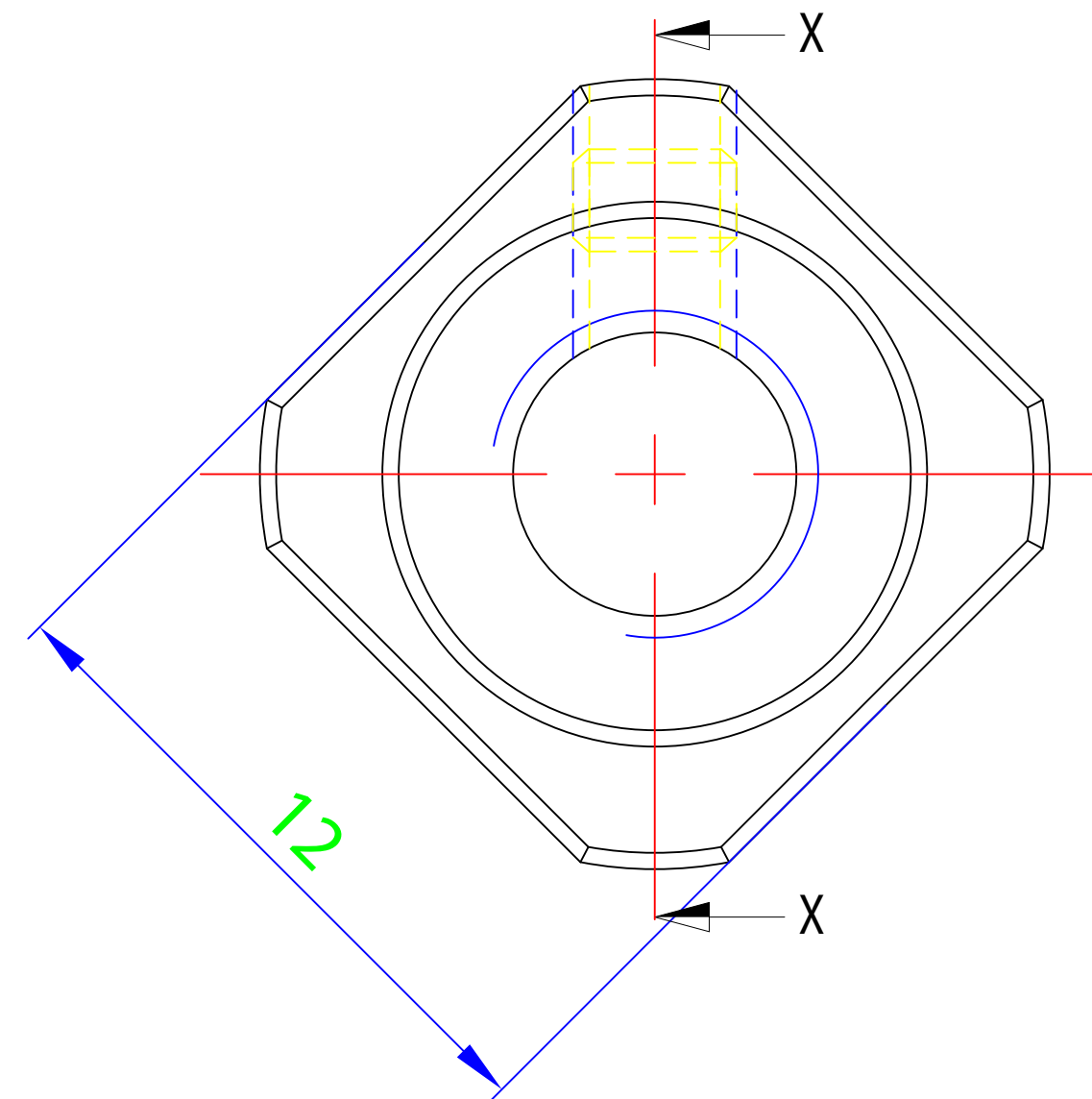
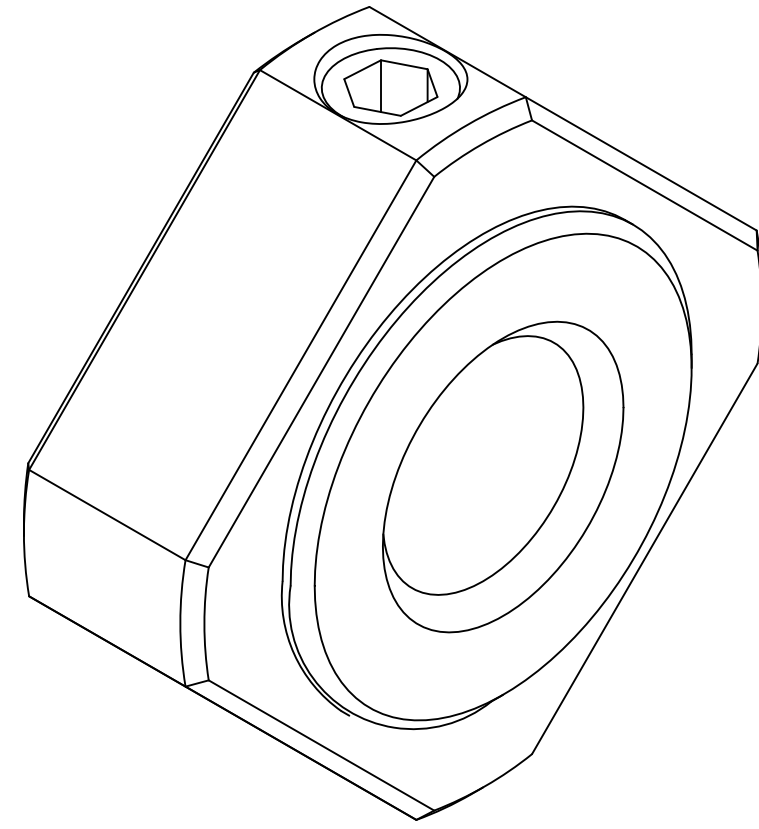

Section X-X

MARK	REASON OF REVISIONS	REVISIONER	CHECKER	DATE

HEAT TREAT

가공치수허용차		
범위	정밀급	보통급
0.5 ~ 6까지	±0.05	±0.1
6 ~ 30까지	±0.1	±0.2
30 ~ 120까지	±0.15	±0.3
120 ~ 315까지	±0.2	±0.5
315 ~ 1000까지	±0.3	±0.8
1000 ~ 2000까지	±0.5	±1.2
지시없는 모따기 및 라운드	R = 0.2~0.3	C = 0.2~0.3

APPROVED BY _____
 CHECKED BY _____
 DRAWN BY _____

TITLE			
RN6 외관도			
SIZE	Dwg.NO. RN6-0000		
A	SCALE	1:1	DATE

NO	DESCRIPTION	SPECIFICATION	MAT'L	Q'TY	REMARK

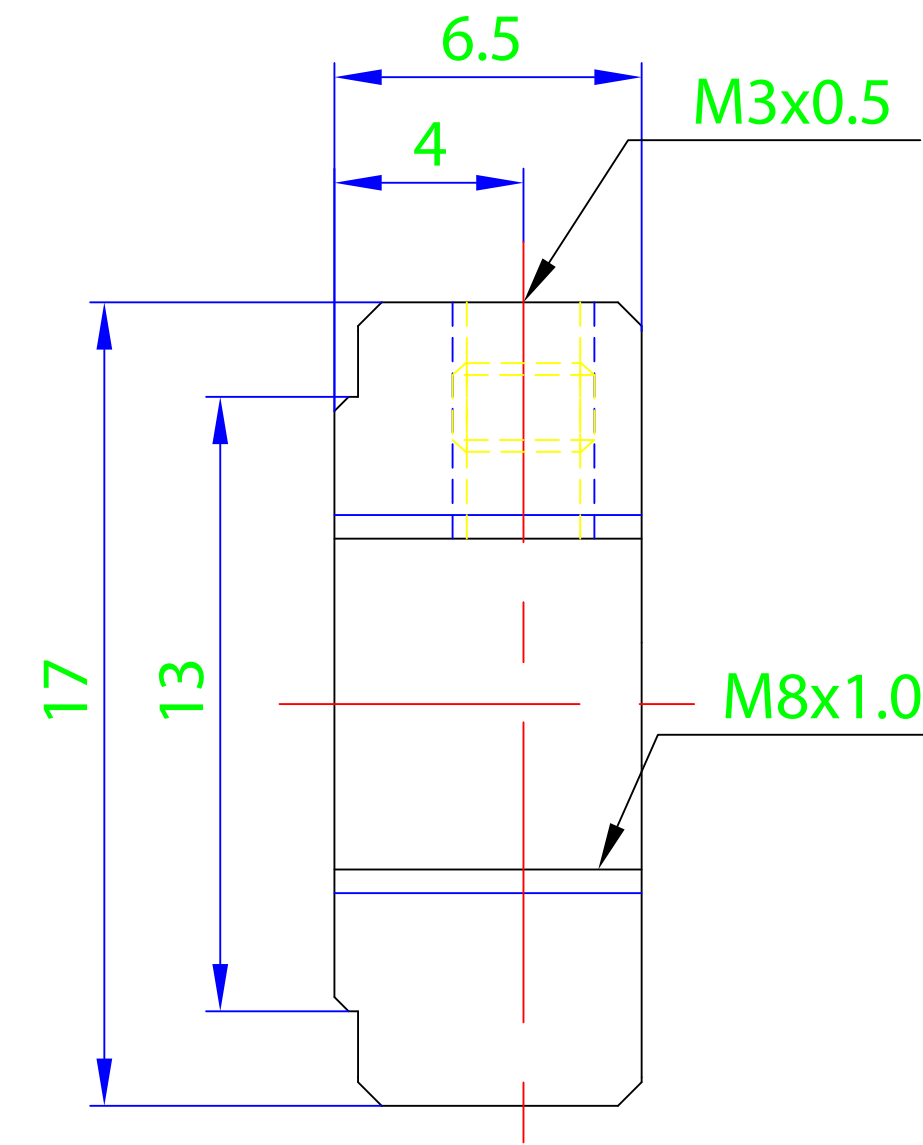
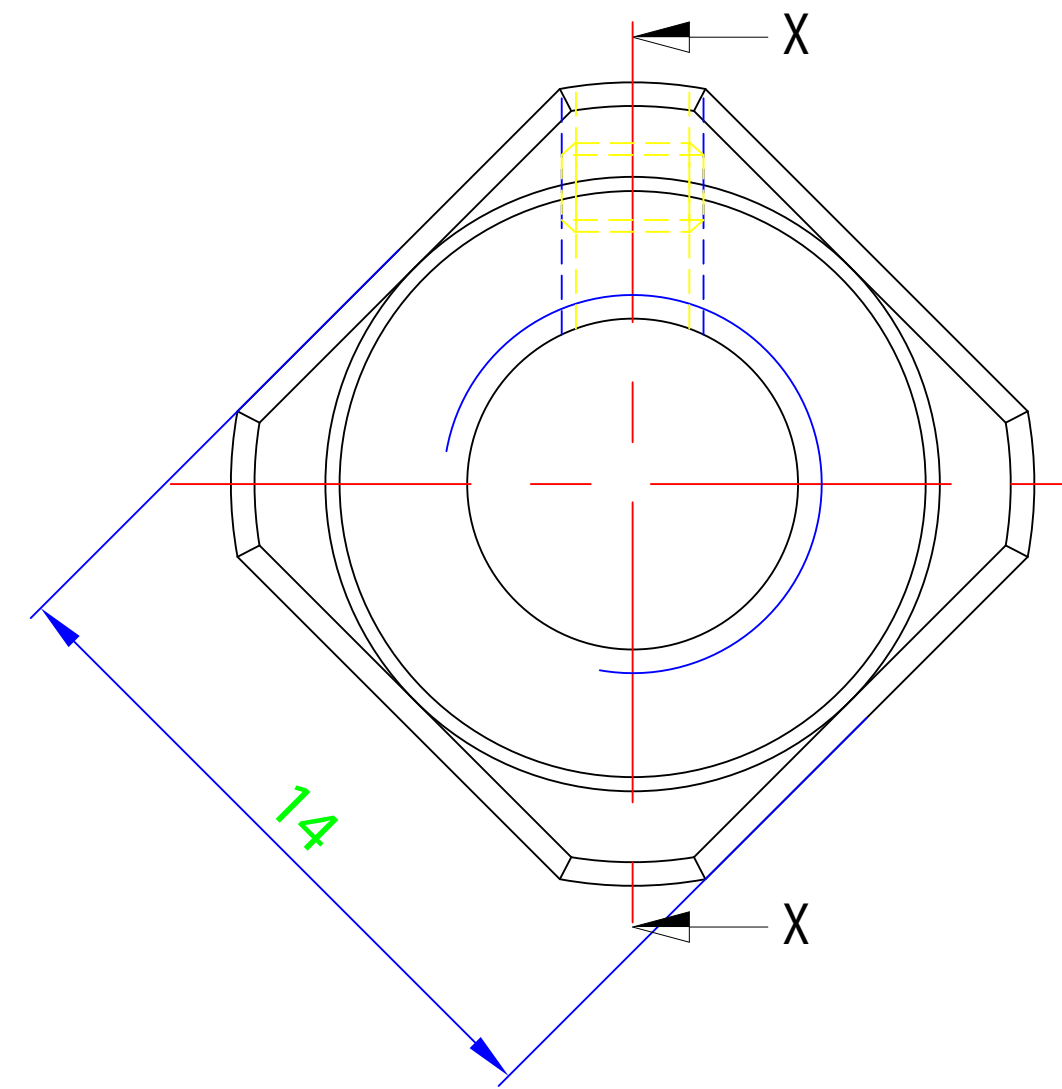
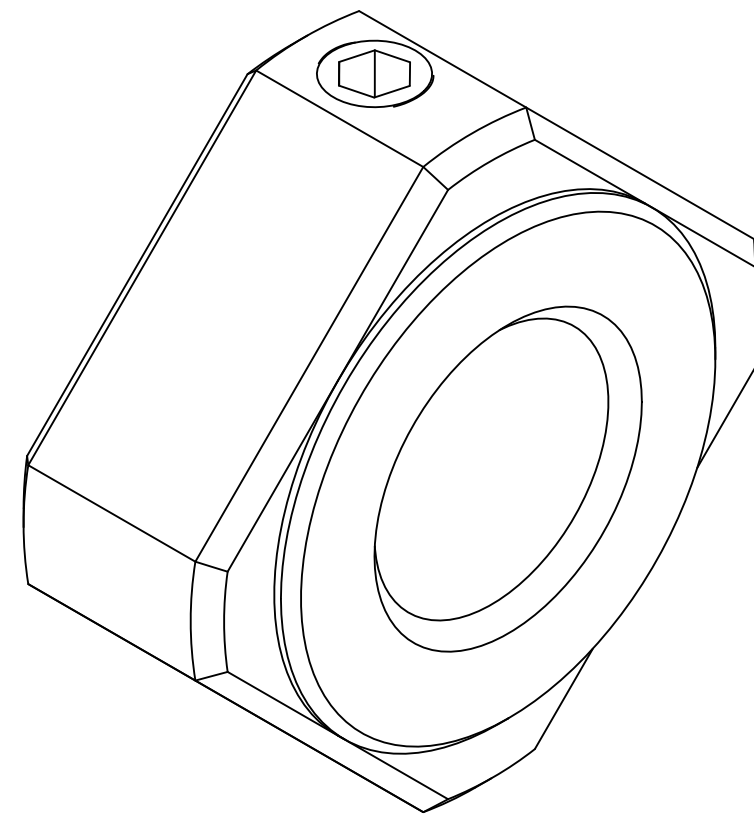

Section X-X

MARK	REASON OF REVISIONS	REVISIONER	CHECKER	DATE

HEAT TREAT

가공치수허용차		
범위	정밀급	보통급
0.5 ~ 6까지	±0.05	±0.1
6 ~ 30까지	±0.1	±0.2
30 ~ 120까지	±0.15	±0.3
120 ~ 315까지	±0.2	±0.5
315 ~ 1000까지	±0.3	±0.8
1000 ~ 2000까지	±0.5	±1.2
지시없는 모따기	R =	0.2~0.3
및 라운드	C =	0.2~0.3

APPROVED BY _____
 CHECKED BY _____
 DRAWN BY _____

SUNGIL

TITLE			
RN8 외관도			
SIZE	Dwg.NO. RN8-0000		
A	SCALE	1:1	DATE

NO	DESCRIPTION	SPECIFICATION	MAT'L	Q'TY	REMARK

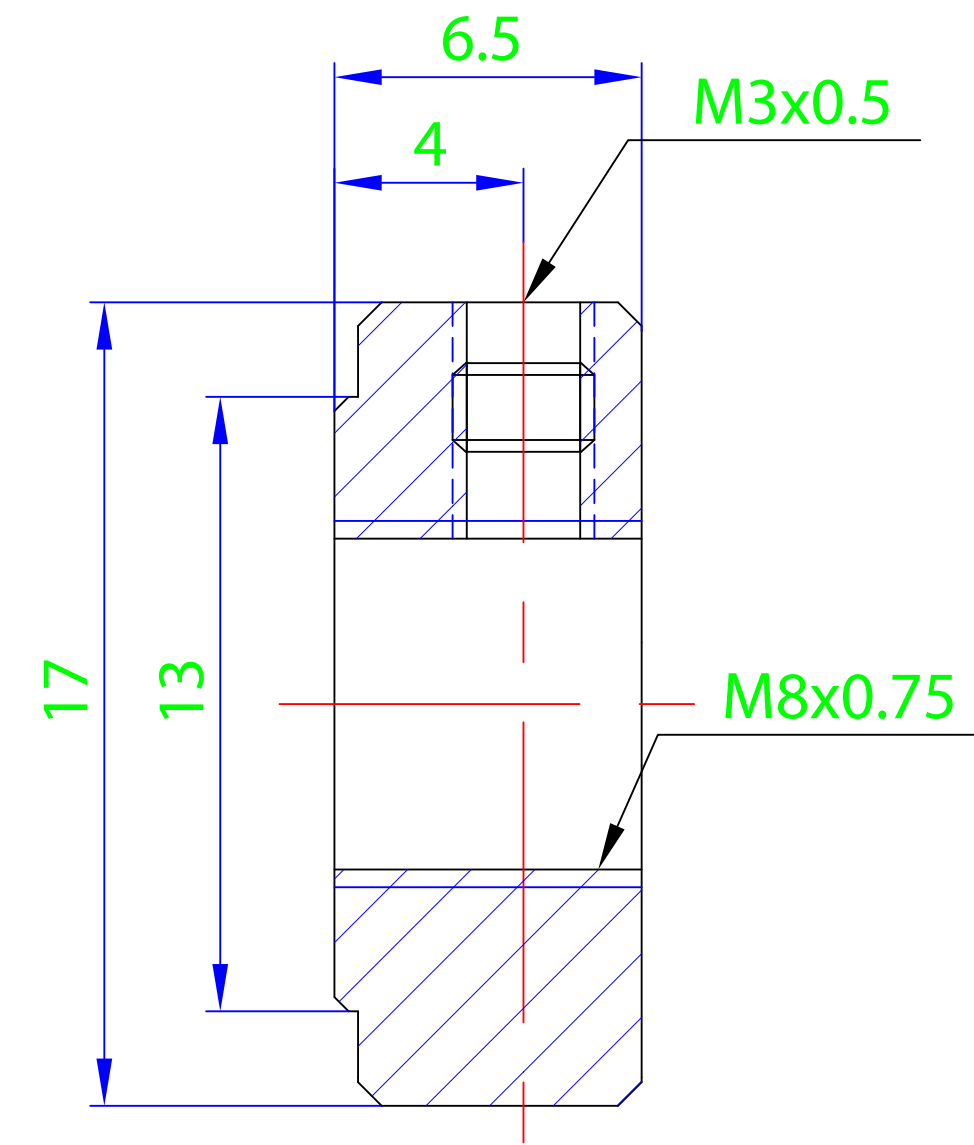
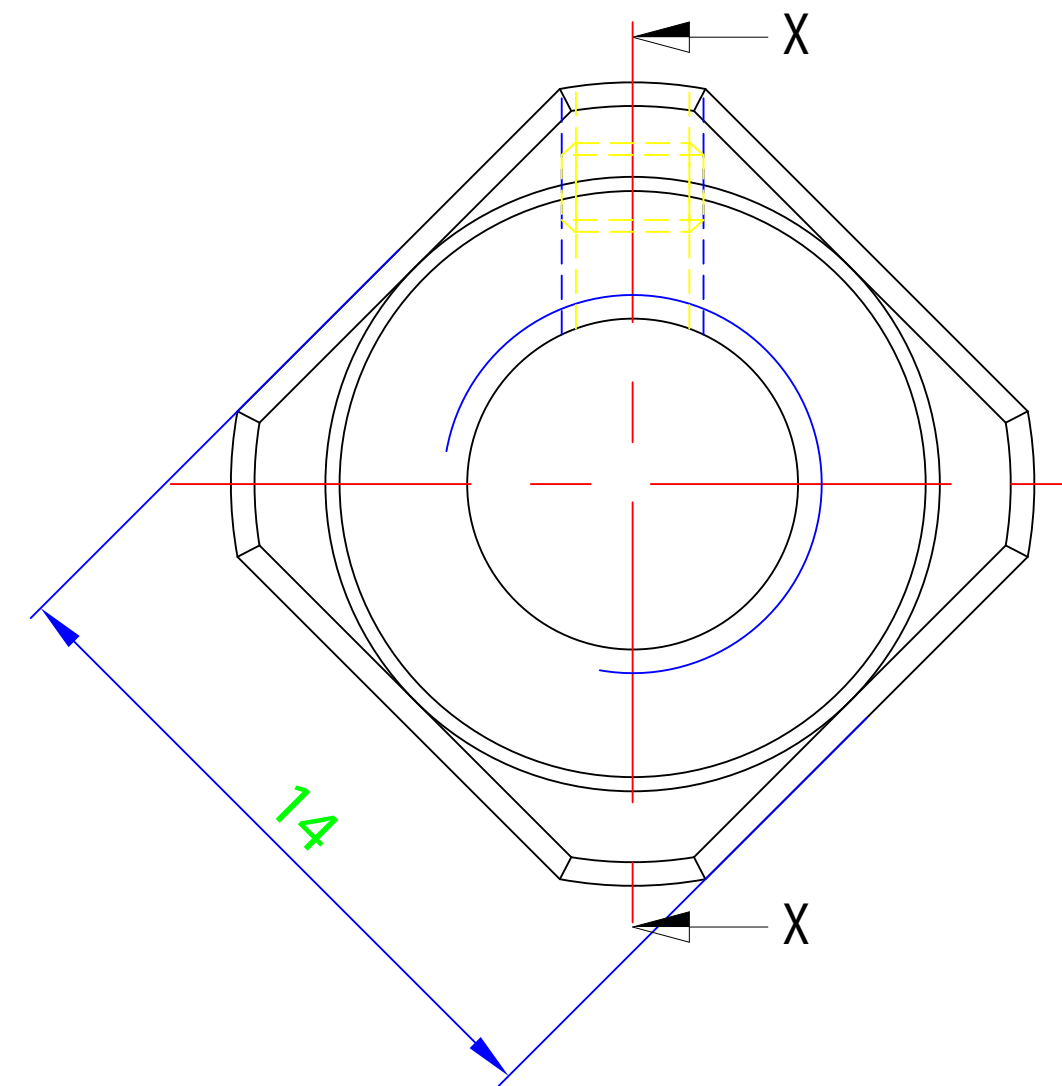
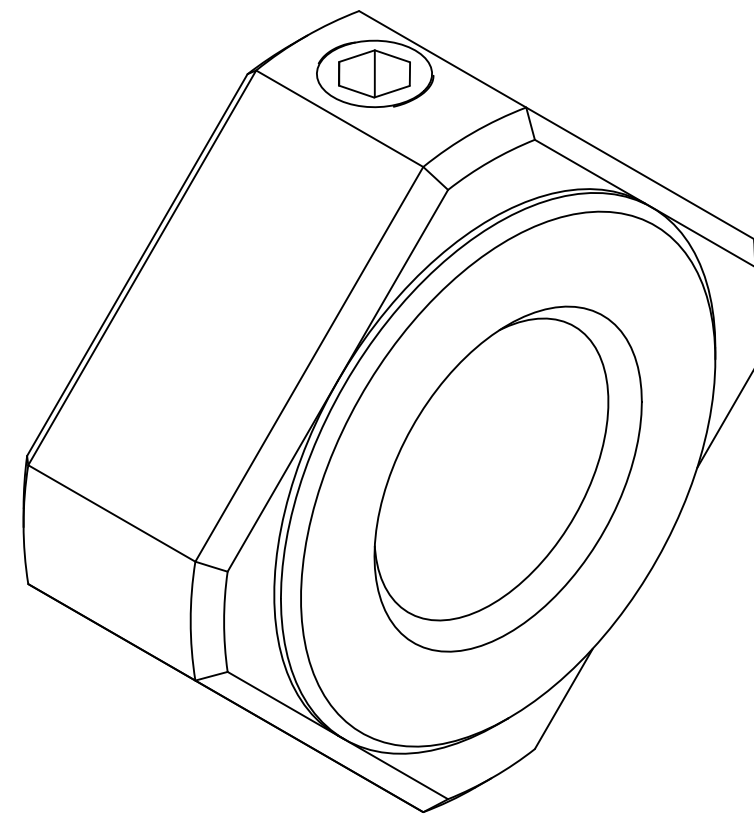

Section X-X

MARK	REASON OF REVISIONS	REVISIONER	CHECKER	DATE

REVISION

가공치수허용차		
범위	정밀급	보통급
0.5 ~ 6까지	±0.05	±0.1
6 ~ 30까지	±0.1	±0.2
30 ~ 120까지	±0.15	±0.3
120 ~ 315까지	±0.2	±0.5
315 ~ 1000까지	±0.3	±0.8
1000 ~ 2000까지	±0.5	±1.2
지시없는 모따기 및 라운드	R = 0.2~0.3	C = 0.2~0.3

APPROVED BY
CHECKED BY
DRAWN BY

TITLE			
RN8_0.75P 외관도			
SIZE	Dwg.NO. RN8_0.75P-0000		
A	SCALE	1:1	DATE

NO	DESCRIPTION	SPECIFICATION	MAT'L	Q'TY	REMARK

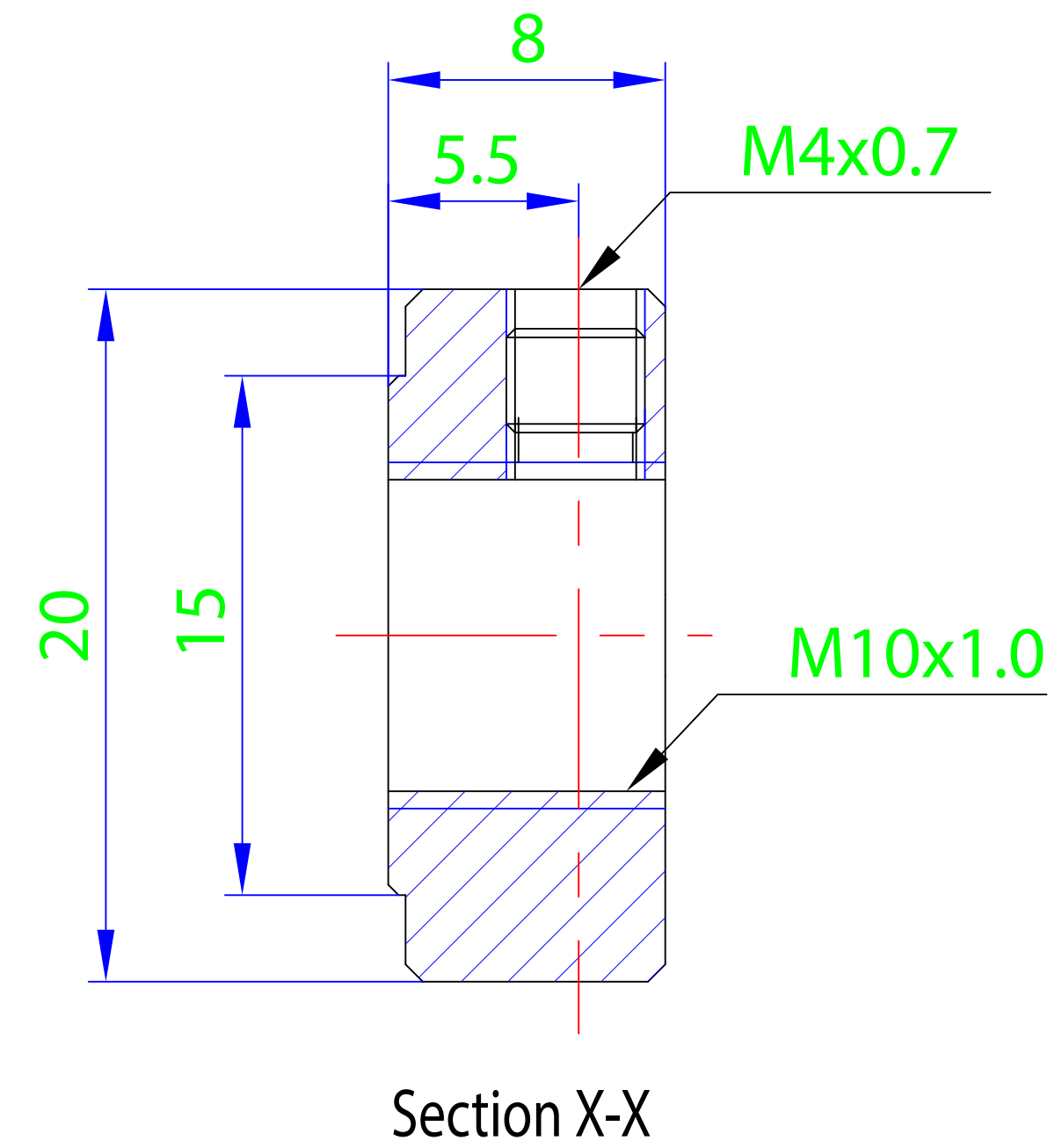
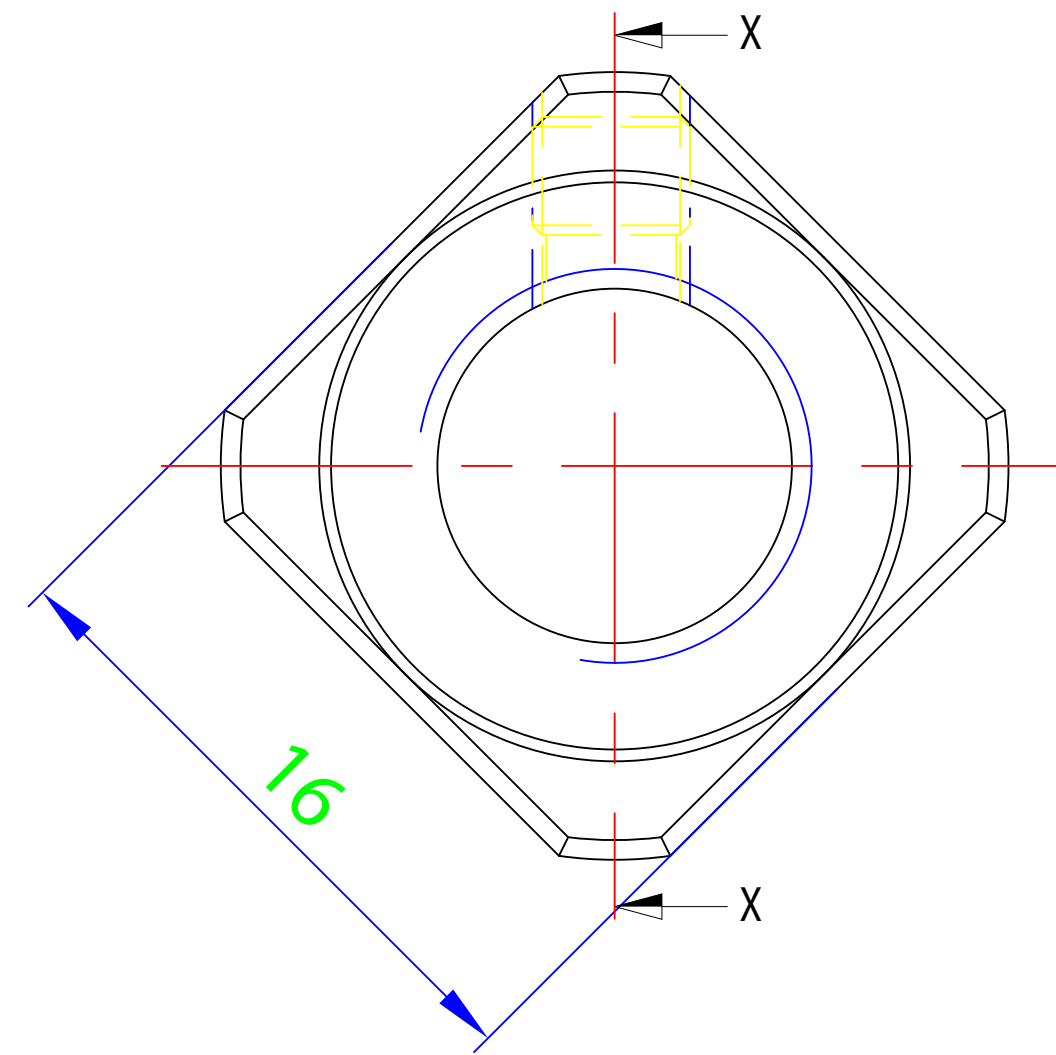
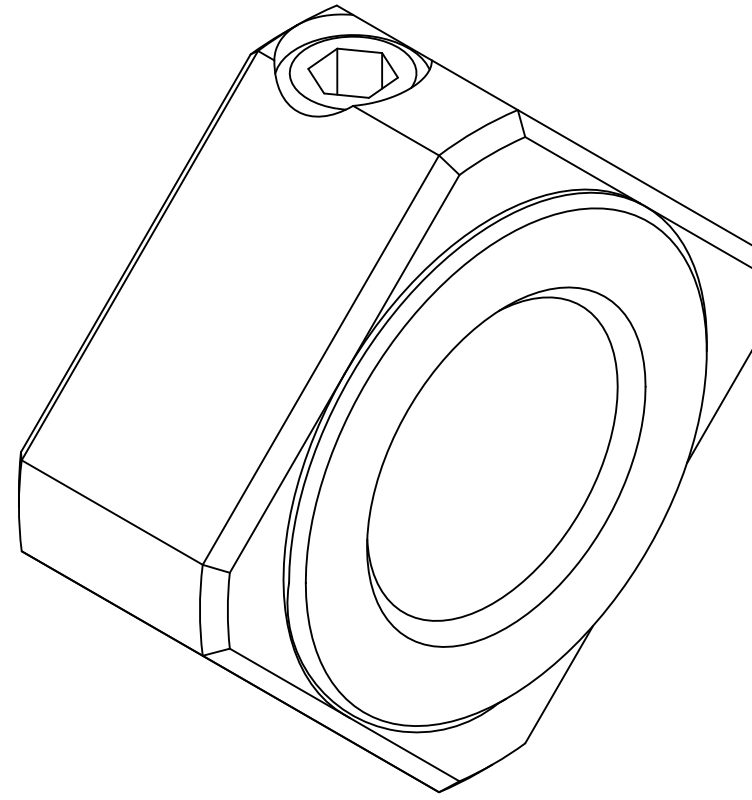

MARK	REASON OF REVISIONS	REVISIONER	CHECKER	DATE

HEAT TREAT

가공치수허용차		
범위	정밀급	보통급
0.5 ~ 6까지	±0.05	±0.1
6 ~ 30까지	±0.1	±0.2
30 ~ 120까지	±0.15	±0.3
120 ~ 315까지	±0.2	±0.5
315 ~ 1000까지	±0.3	±0.8
1000 ~ 2000까지	±0.5	±1.2
지시없는 모따기 및 라운드	R = 0.2~0.3	C = 0.2~0.3

APPROVED BY
 CHECKED BY
 DRAWN BY
SUNGIL

TITLE			
RN10 외관도			
SIZE	Dwg.NO. RN10-0000		
A	SCALE	1:1	DATE

NO	DESCRIPTION	SPECIFICATION	MAT'L	Q'TY	REMARK

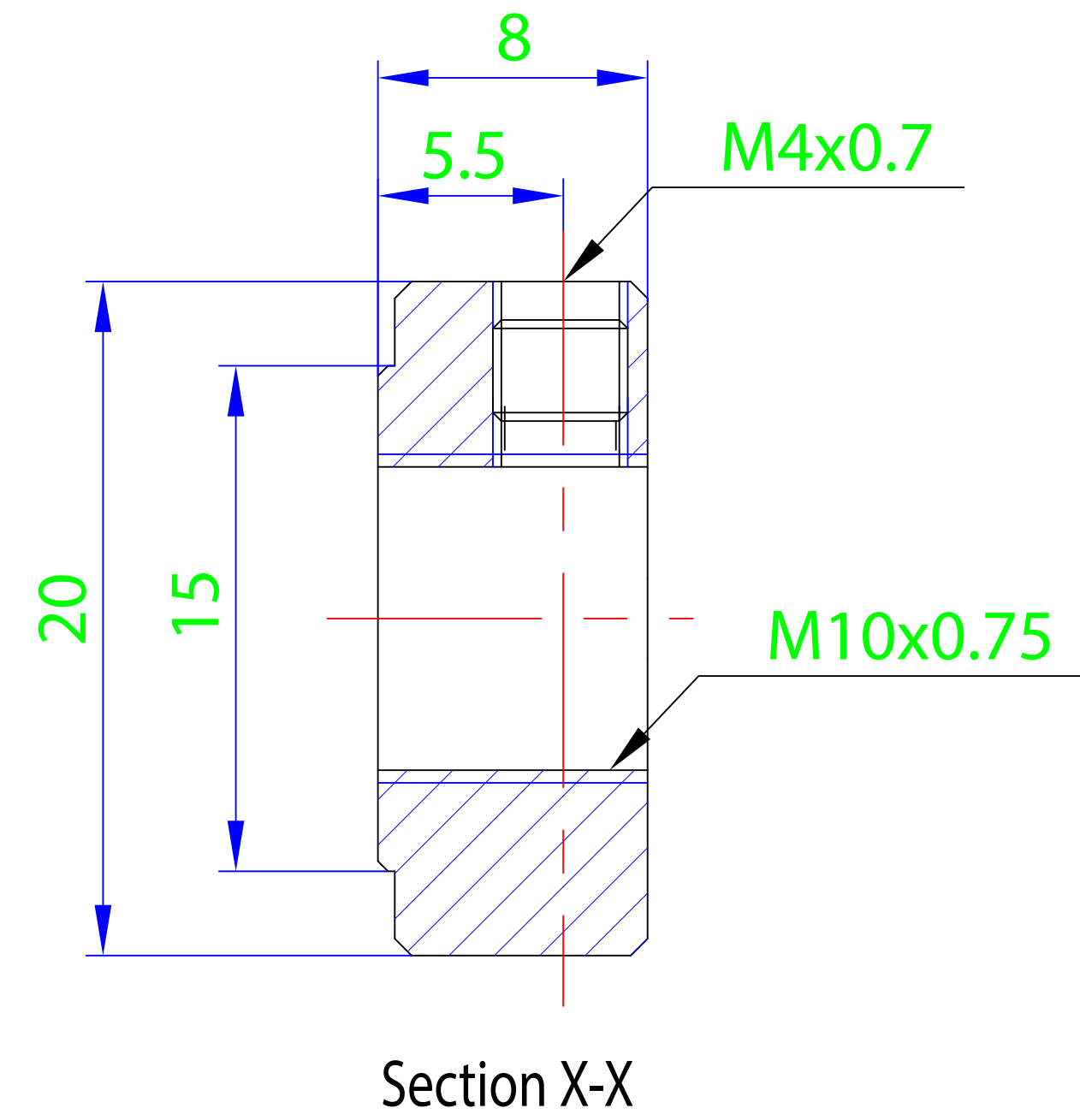
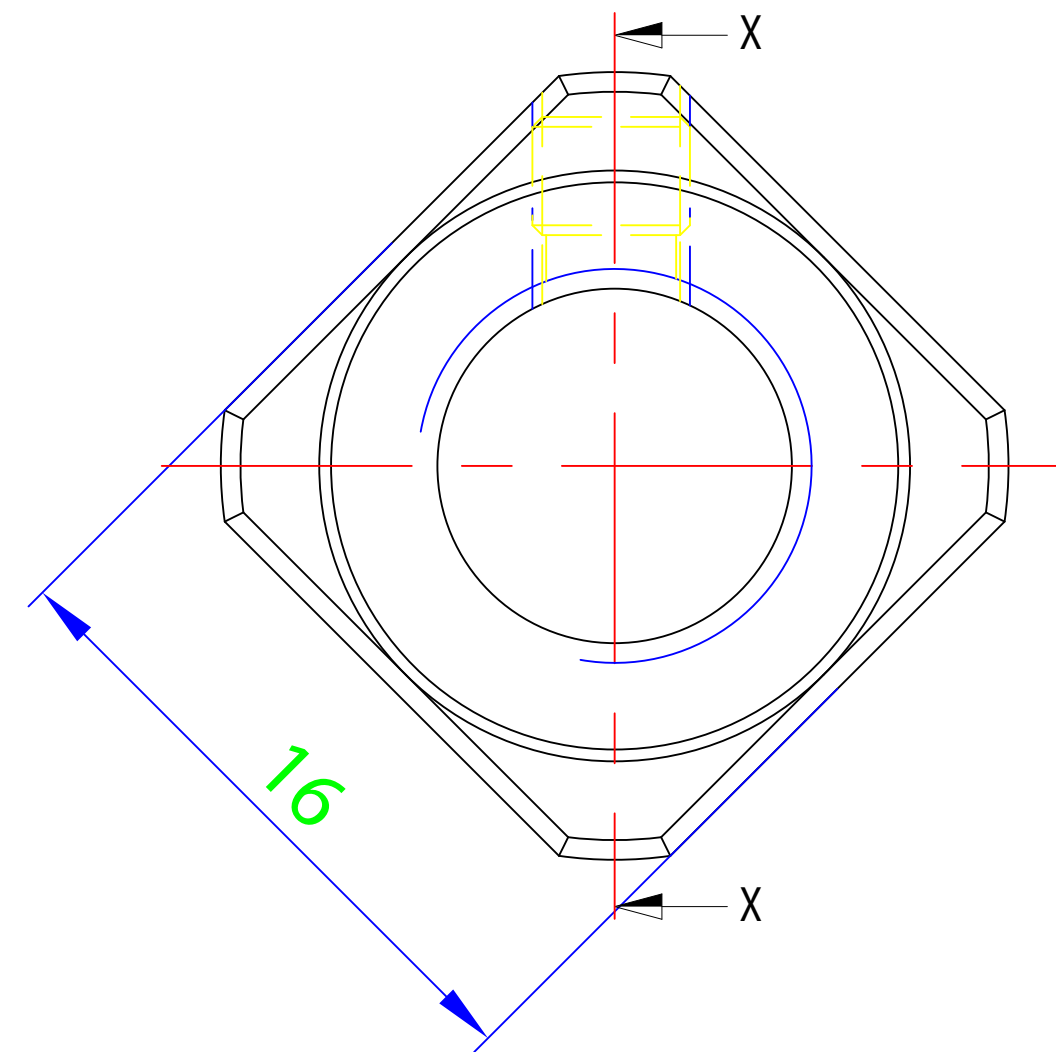
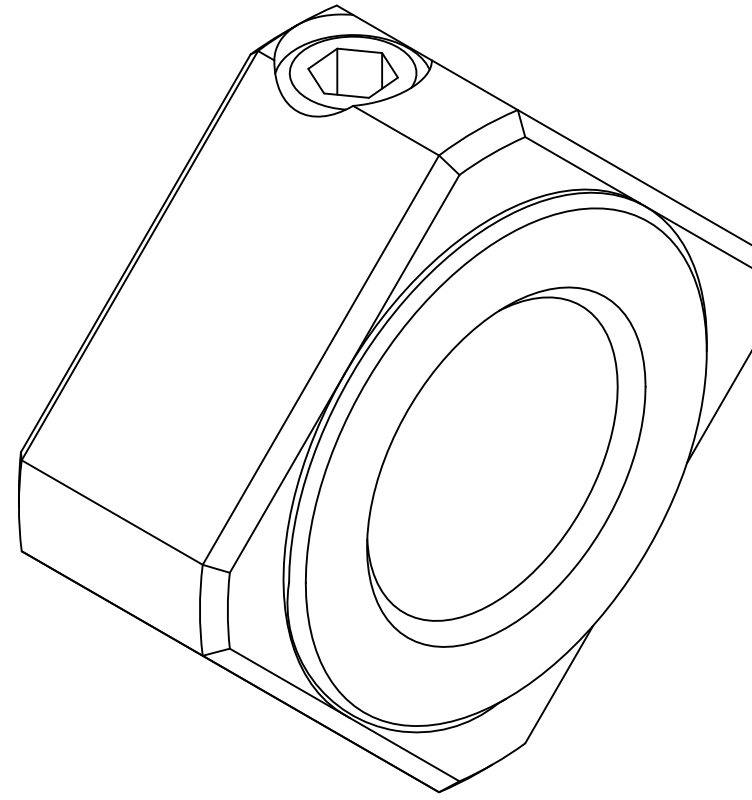

MARK	REASON OF REVISIONS	REVISIONER	CHECKER	DATE

REVISION

가공치수허용차		
범위	정밀급	보통급
0.5 ~ 6까지	±0.05	±0.1
6 ~ 30까지	±0.1	±0.2
30 ~ 120까지	±0.15	±0.3
120 ~ 315까지	±0.2	±0.5
315 ~ 1000까지	±0.3	±0.8
1000 ~ 2000까지	±0.5	±1.2
지시없는 모따기 및 라운드	R = 0.2~0.3	C = 0.2~0.3

APPROVED BY
CHECKED BY
DRAWN BY

SUNGIL

TITLE			
RN10_0.75P 외관도			
SIZE	Dwg.NO. RN10_0.75P-0000		
A	SCALE	1:1	DATE

NO	DESCRIPTION	SPECIFICATION	MAT'L	Q'TY	REMARK

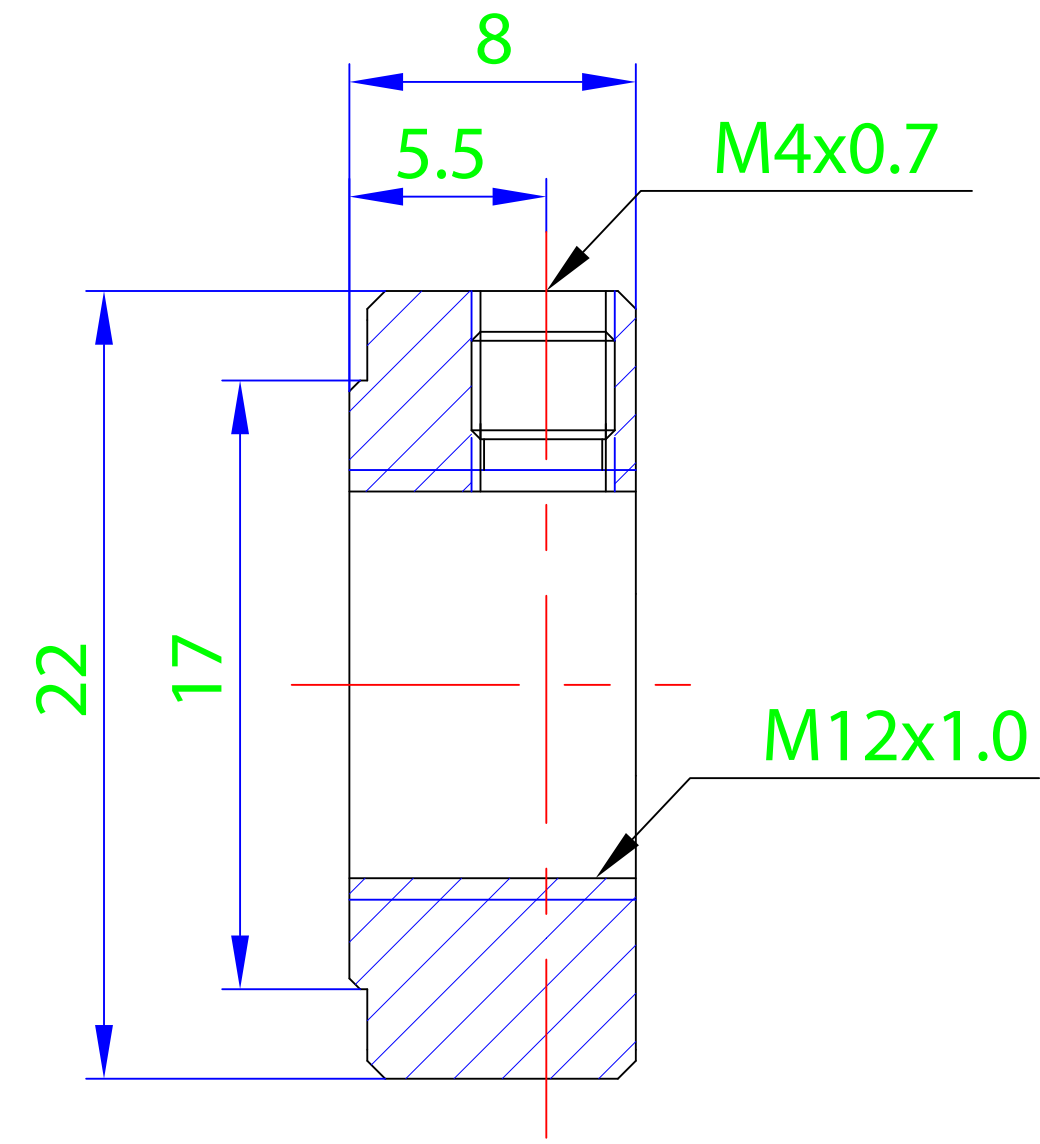
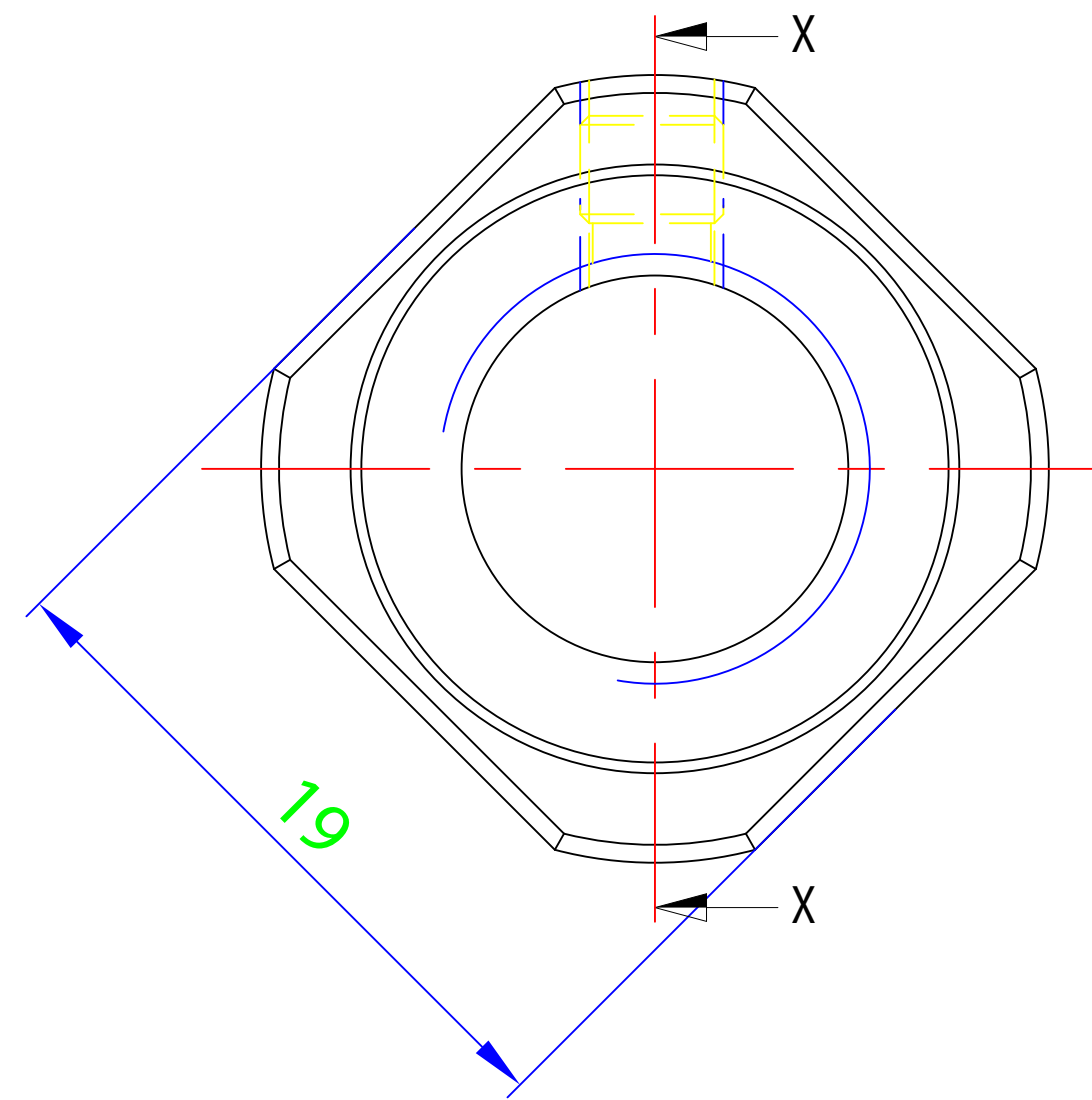
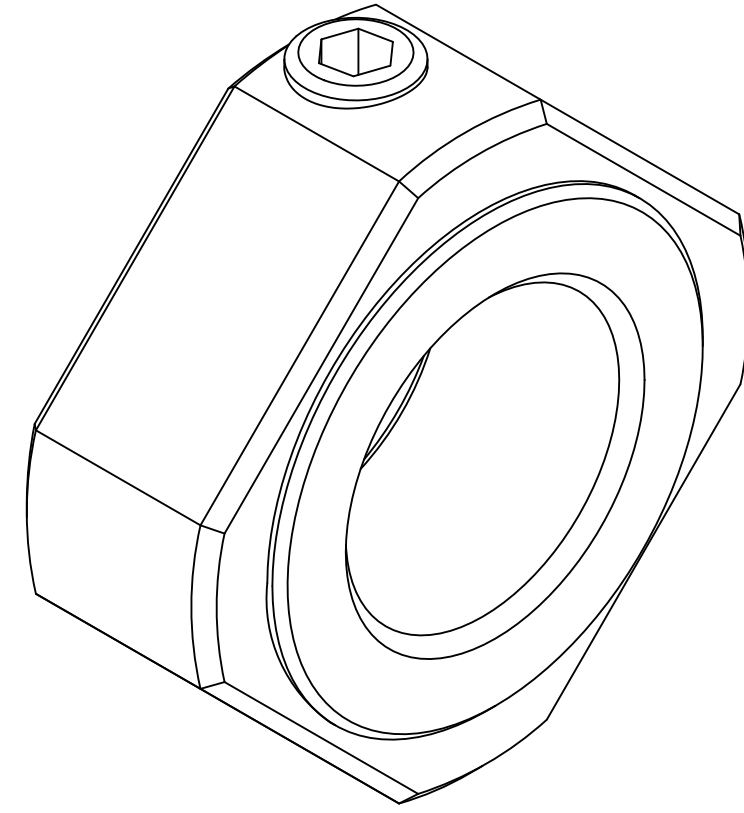

Section X-X

MARK	REASON OF REVISIONS	REVISIONER	CHECKER	DATE

HEAT TREAT	APPROVED FINISH

가공치수허용차		
범위	정밀급	보통급
0.5 ~ 6까지	±0.05	±0.1
6 ~ 30까지	±0.1	±0.2
30 ~ 120까지	±0.15	±0.3
120 ~ 315까지	±0.2	±0.5
315 ~ 1000까지	±0.3	±0.8
1000 ~ 2000까지	±0.5	±1.2
지시없는 모따기 및 라운드	R = 0.2~0.3	C = 0.2~0.3

APPROVED BY _____
 CHECKED BY _____
 DRAWN BY _____

SUNGIL

TITLE			
RN12 외관도			
SIZE	Dwg.NO. RN12-0000		
A	SCALE	1:1	DATE

NO	DESCRIPTION	SPECIFICATION	MAT'L	Q'TY	REMARK

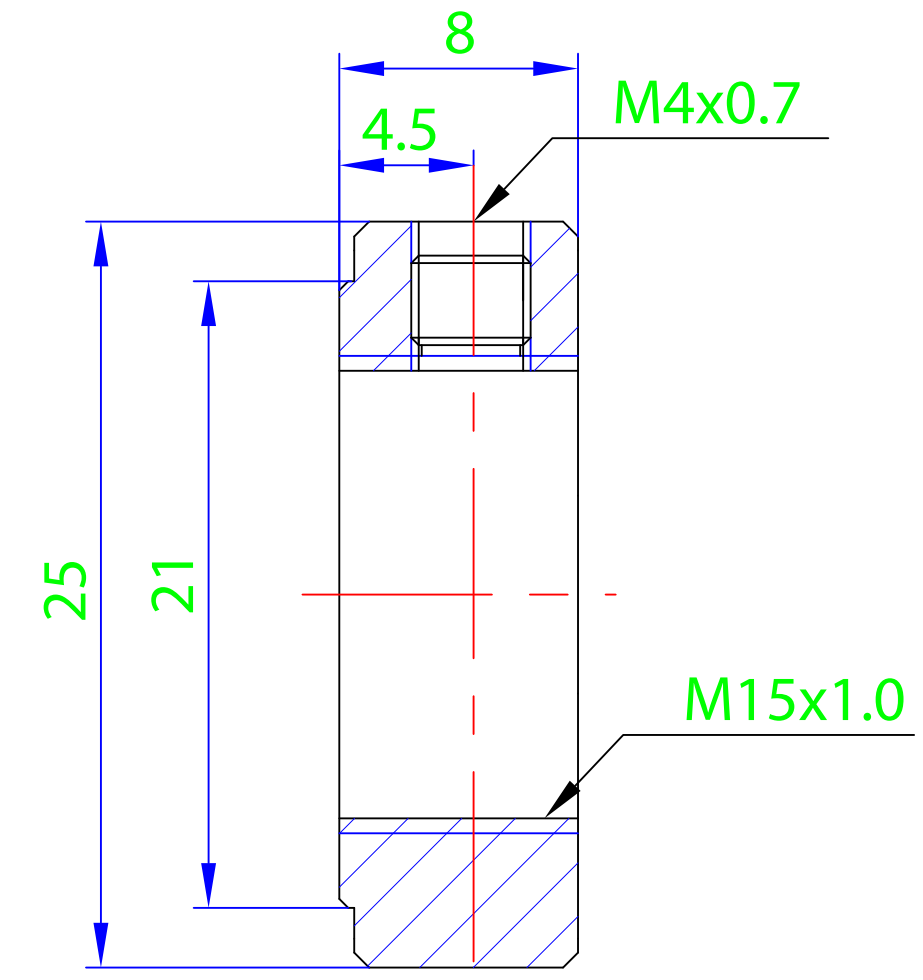
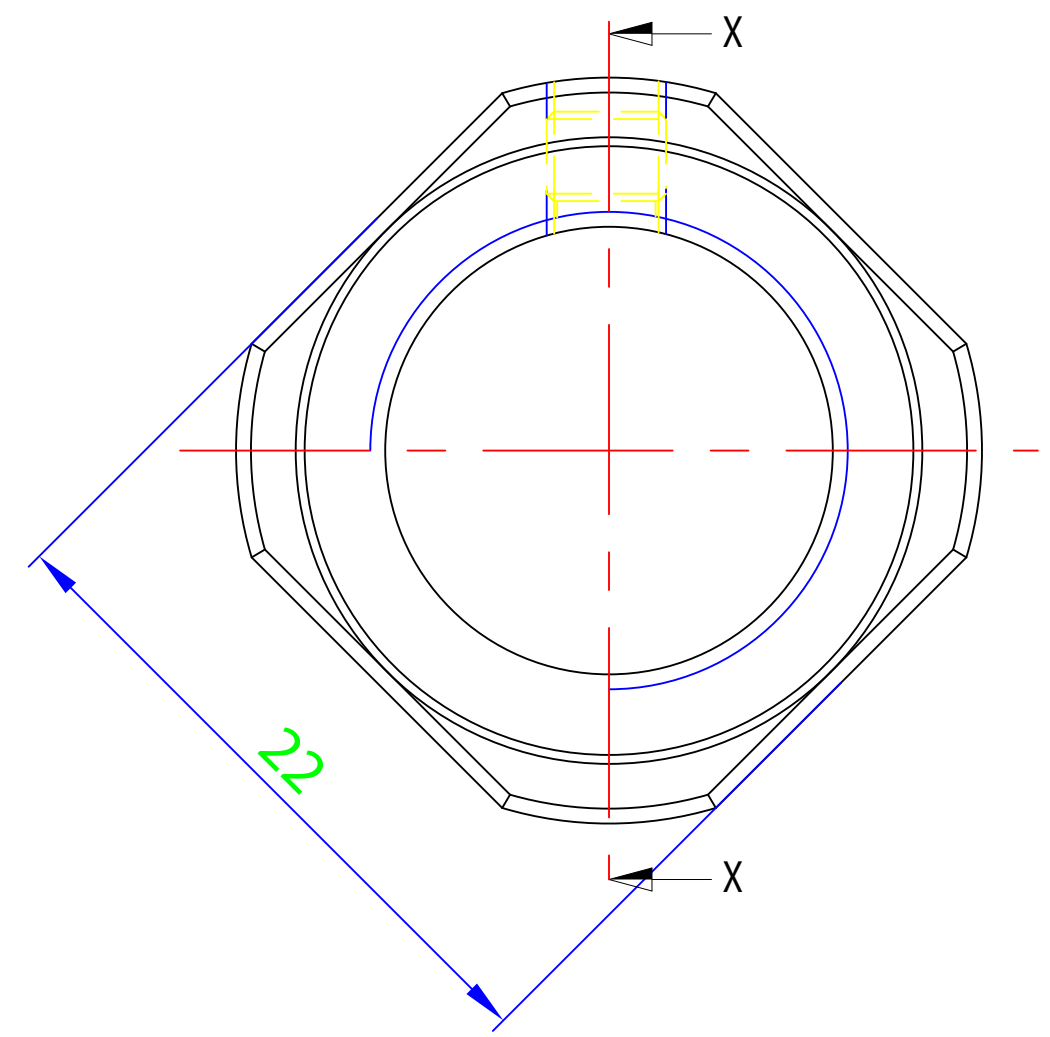
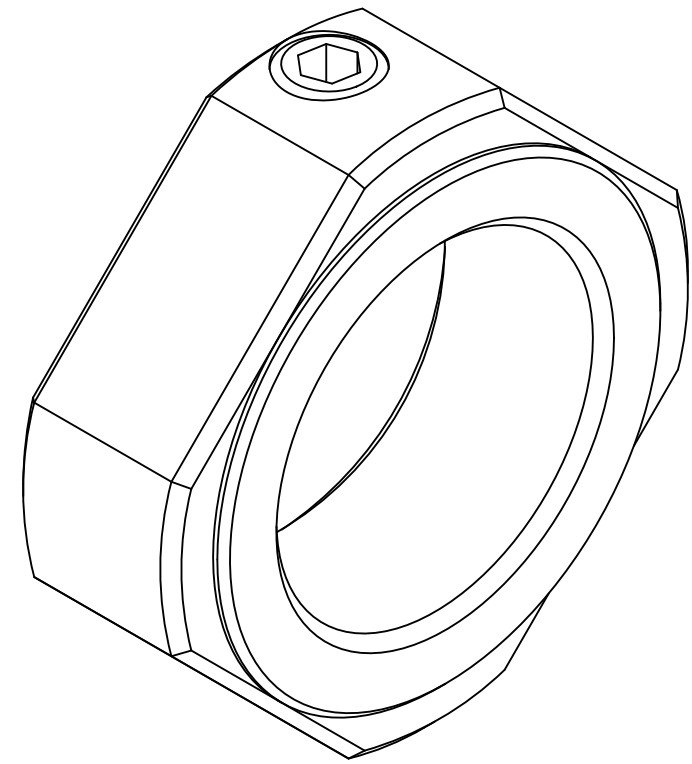

Section X-X

MARK	REASON OF REVISIONS	REVISIONER	CHECKER	DATE

가공치수허용차		
범위	정밀급	보통급
0.5 ~ 6까지	±0.05	±0.1
6 ~ 30까지	±0.1	±0.2
30 ~ 120까지	±0.15	±0.3
120 ~ 315까지	±0.2	±0.5
315 ~ 1000까지	±0.3	±0.8
1000 ~ 2000까지	±0.5	±1.2
지시없는 모따기	R =	0.2~0.3
및 라운드	C =	0.2~0.3

APPROVED BY	
CHECKED BY	
DRAWN BY	



TITLE			
RN15 외관도			
SIZE	Dwg.NO. RN15-0000		
A	SCALE	1:1	DATE

NO	DESCRIPTION	SPECIFICATION	MAT'L	Q'TY	REMARK

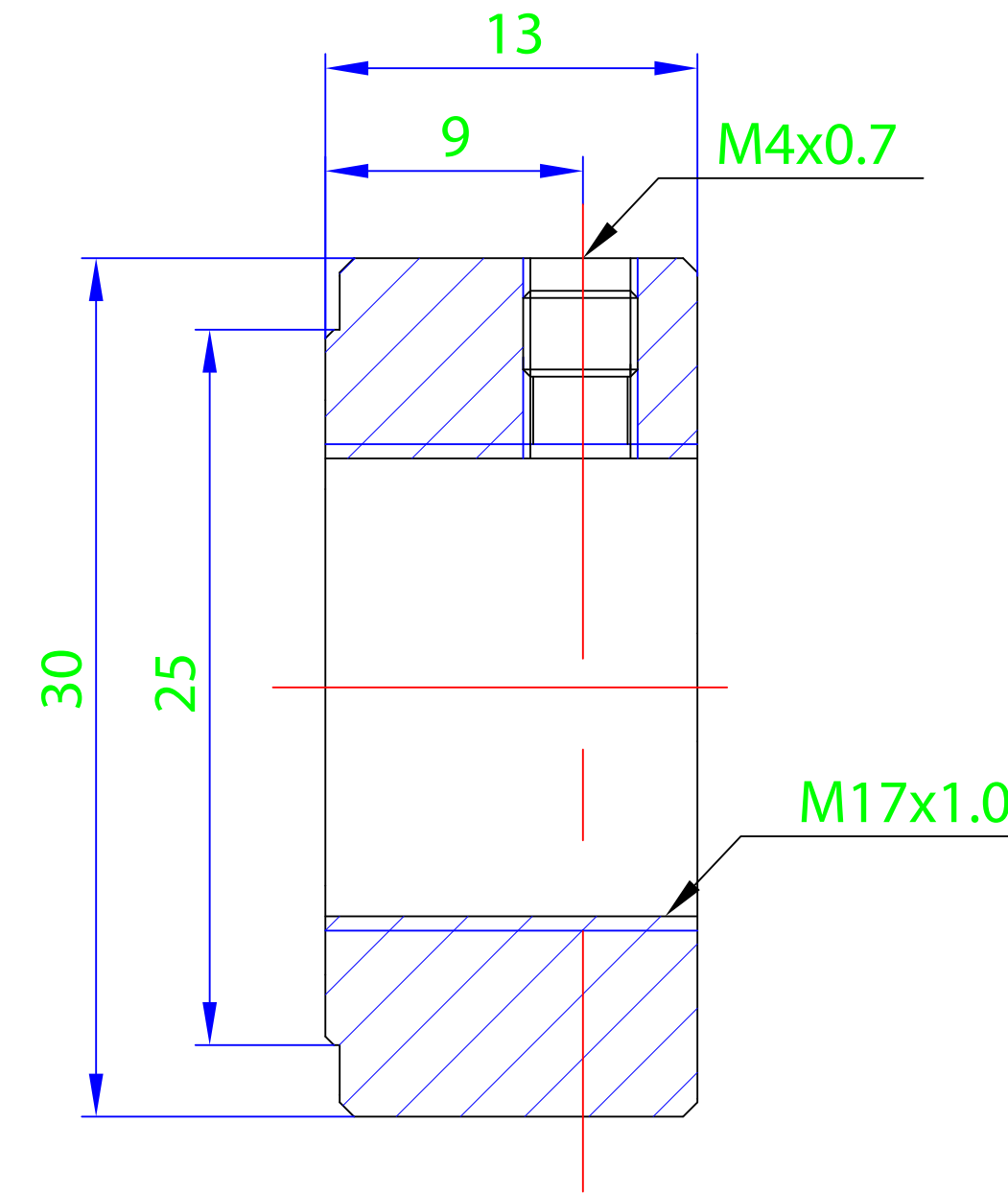
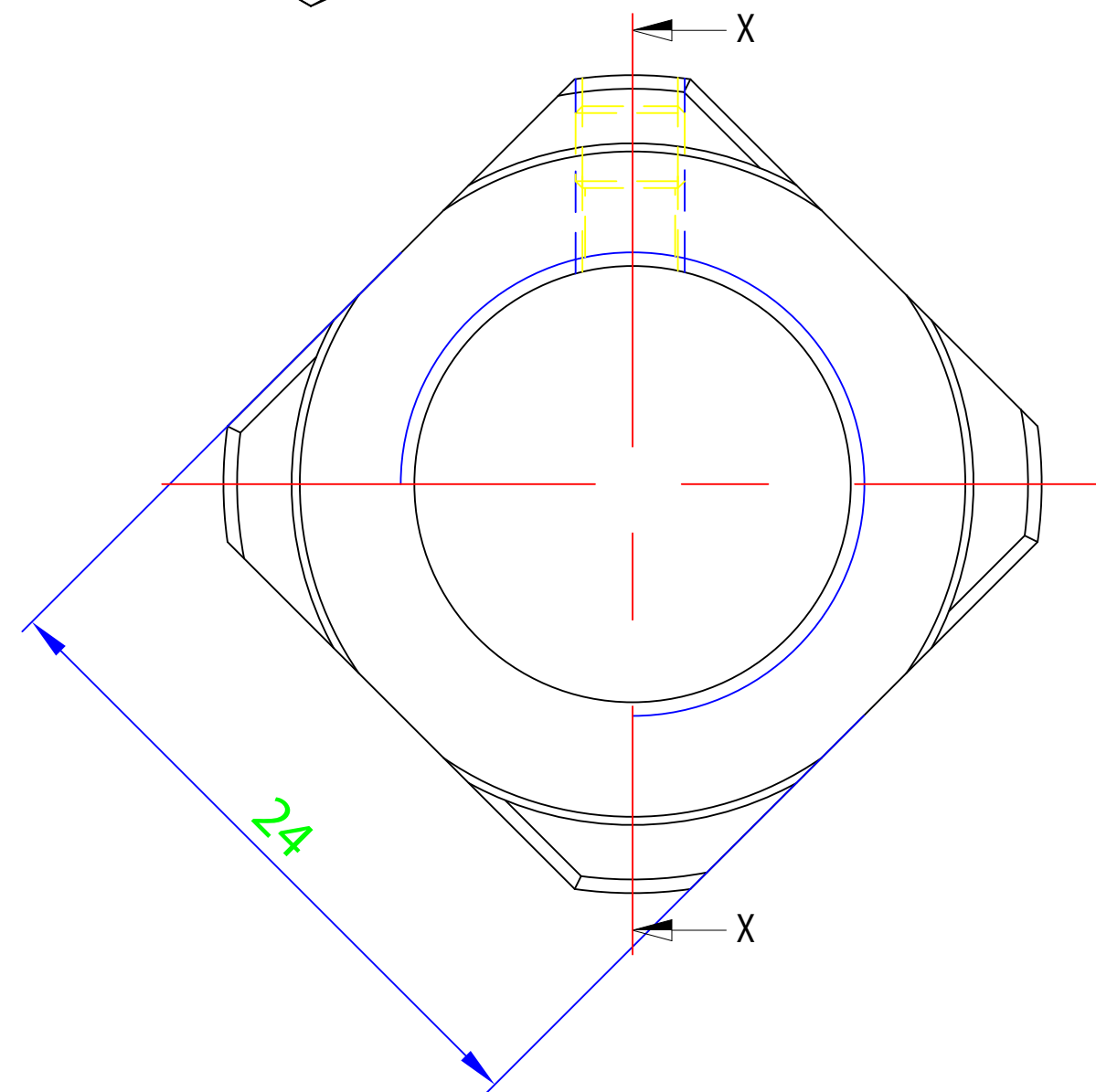
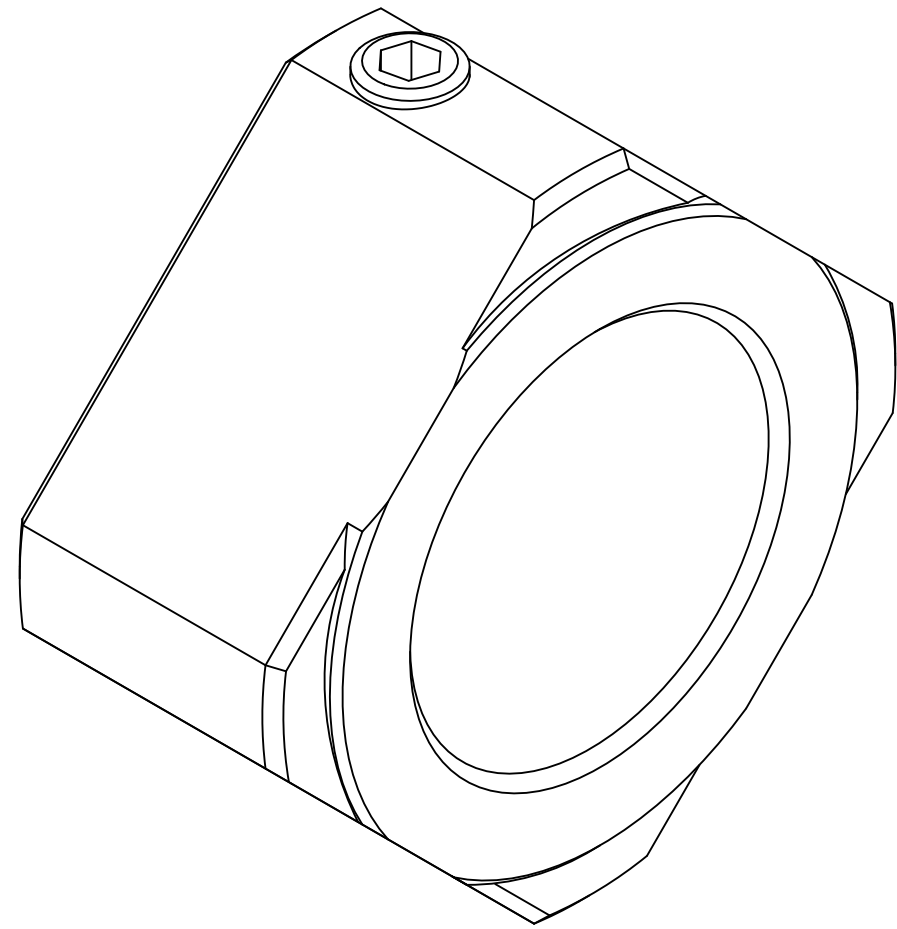

Section X-X

가공치수허용차		
범위	정밀급	보통급
0.5 ~ 6까지	±0.05	±0.1
6 ~ 30까지	±0.1	±0.2
30 ~ 120까지	±0.15	±0.3
120 ~ 315까지	±0.2	±0.5
315 ~ 1000까지	±0.3	±0.8
1000 ~ 2000까지	±0.5	±1.2
지시없는 모따기 및 라운드	R = 0.2~0.3	C = 0.2~0.3

APPROVED BY
CHECKED BY
DRAWN BY

TITLE
RN17 외관도

MARK	REASON OF REVISIONS	REVISIONER	CHECKER	DATE

HEAT TREAT
APPROVED FINISH

SIZE A
Dwg.NO. RN17-0000
SCALE 1:1
DATE

NO	DESCRIPTION	SPECIFICATION	MAT'L	Q'TY	REMARK

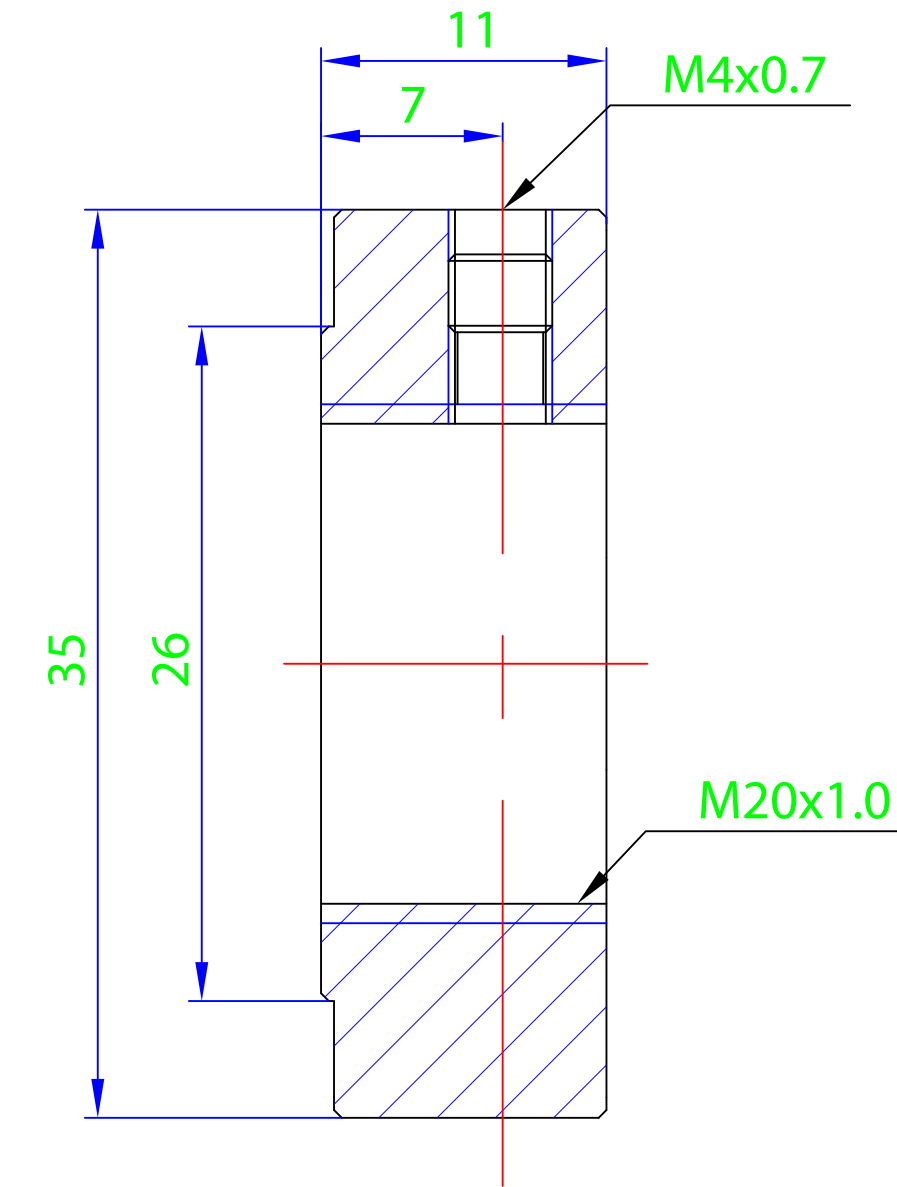
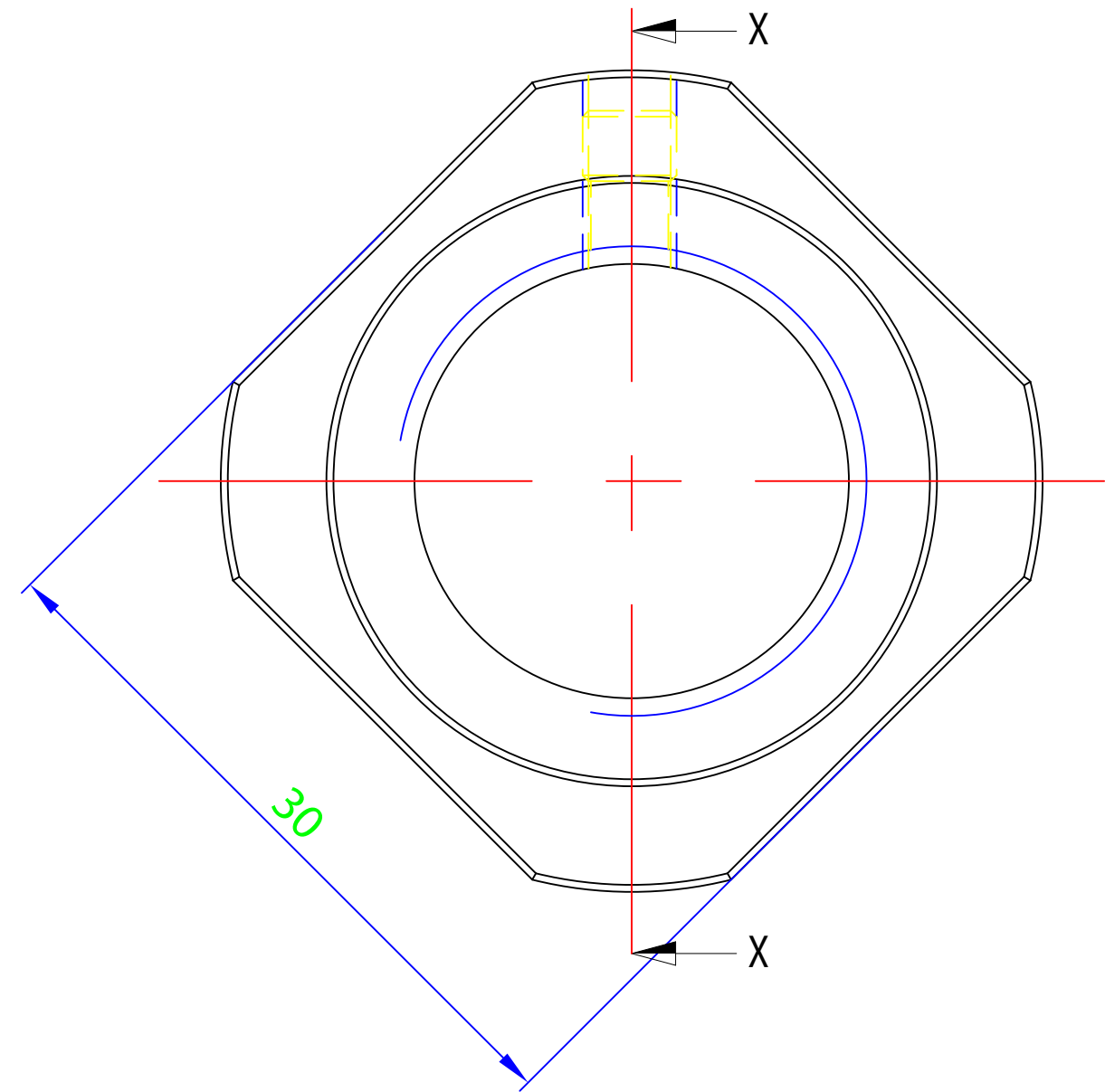
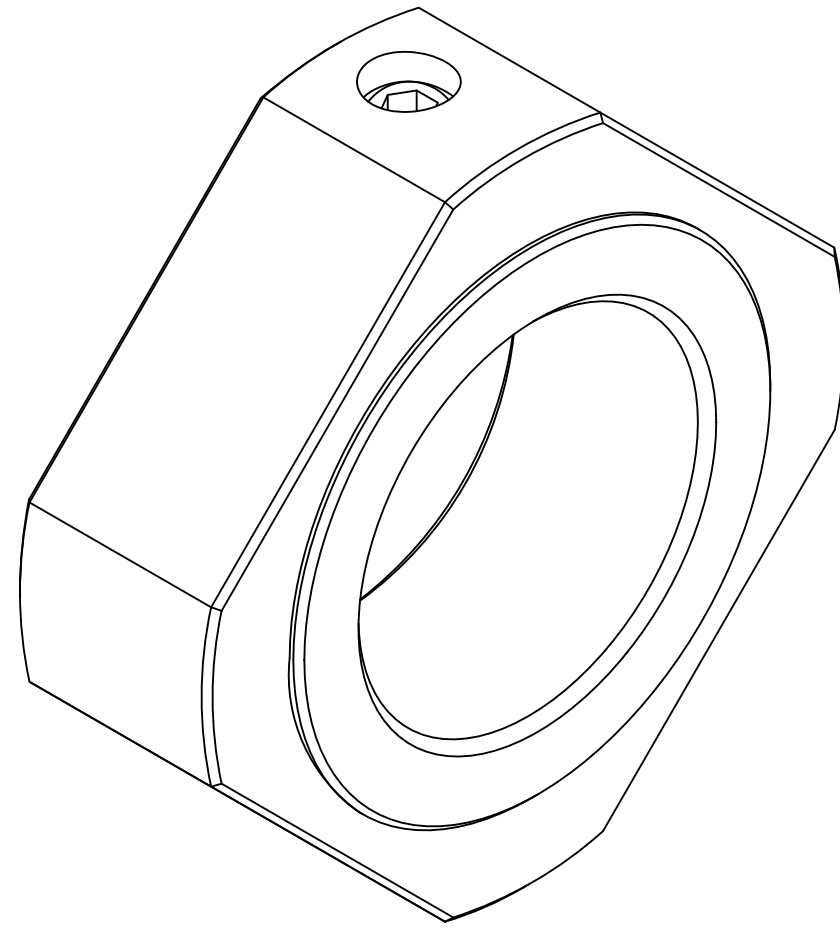

Section X-X

MARK	REASON OF REVISIONS	REVISIONER	CHECKER	DATE

REVISION

가공치수허용차		
범위	정밀급	보통급
0.5 ~ 6까지	±0.05	±0.1
6 ~ 30까지	±0.1	±0.2
30 ~ 120까지	±0.15	±0.3
120 ~ 315까지	±0.2	±0.5
315 ~ 1000까지	±0.3	±0.8
1000 ~ 2000까지	±0.5	±1.2
지시없는 모따기 및 라운드	R = 0.2~0.3	C = 0.2~0.3

APPROVED BY	
CHECKED BY	
DRAWN BY	



TITLE	RN20 외관도		
SIZE	A		

Dwg.NO.	RN20-0000		
SCALE	1:1	DATE	

NO	DESCRIPTION	SPECIFICATION	MAT'L	Q'TY	REMARK

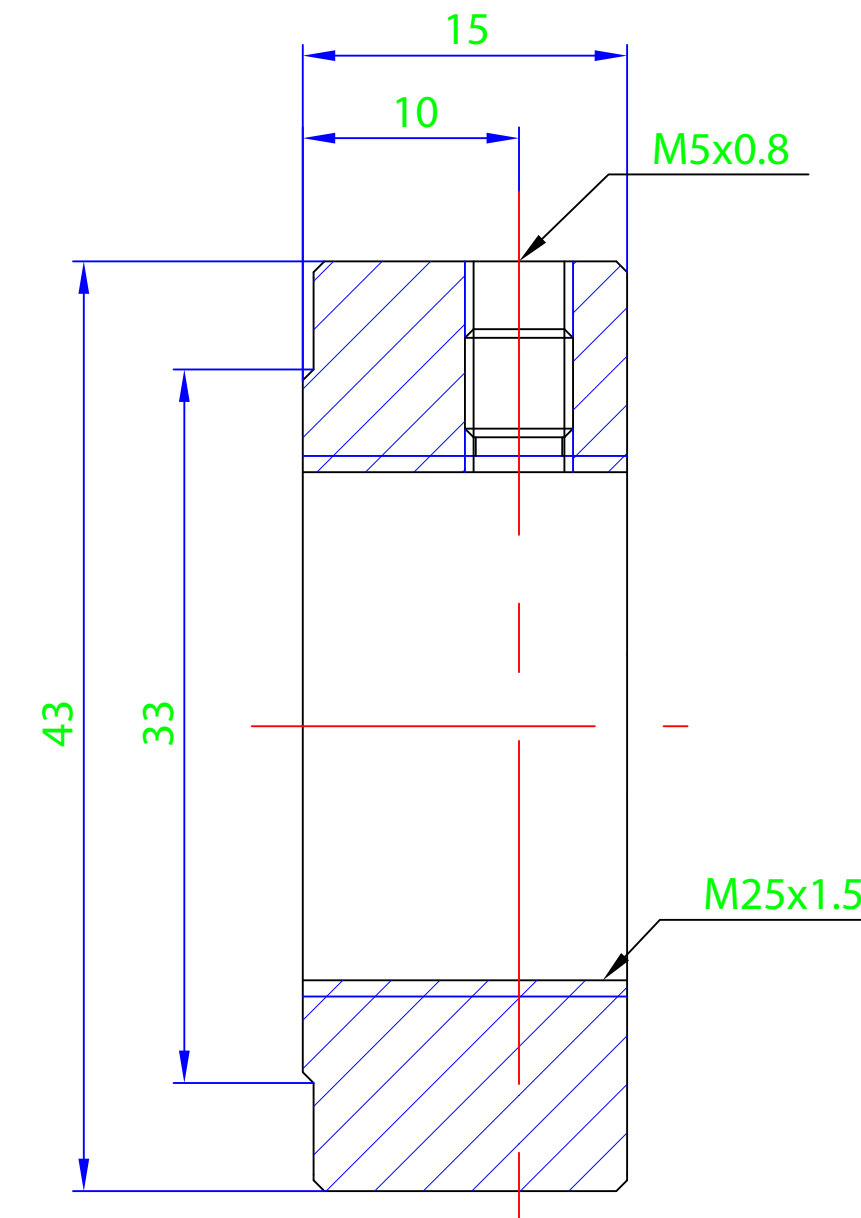
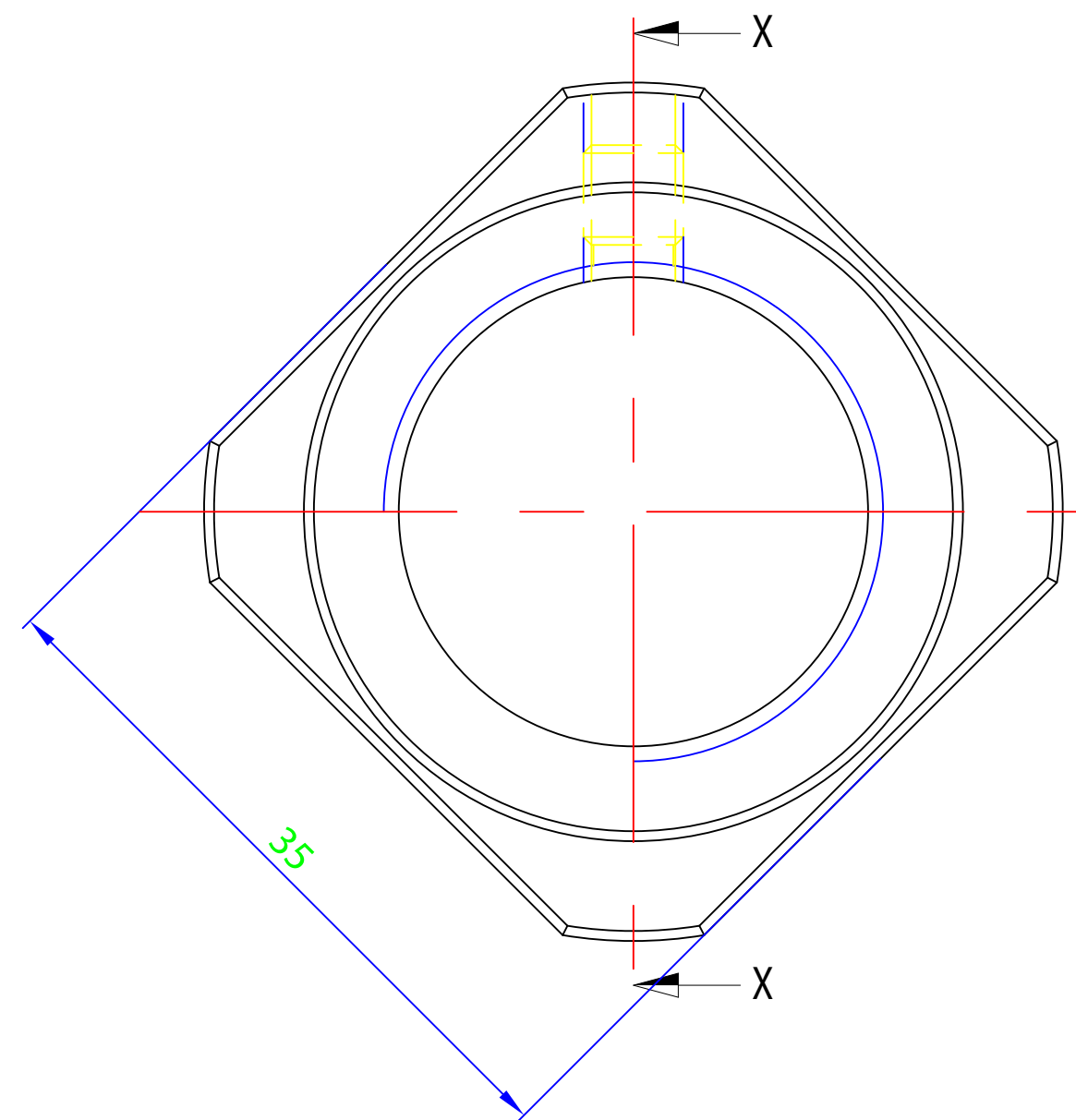
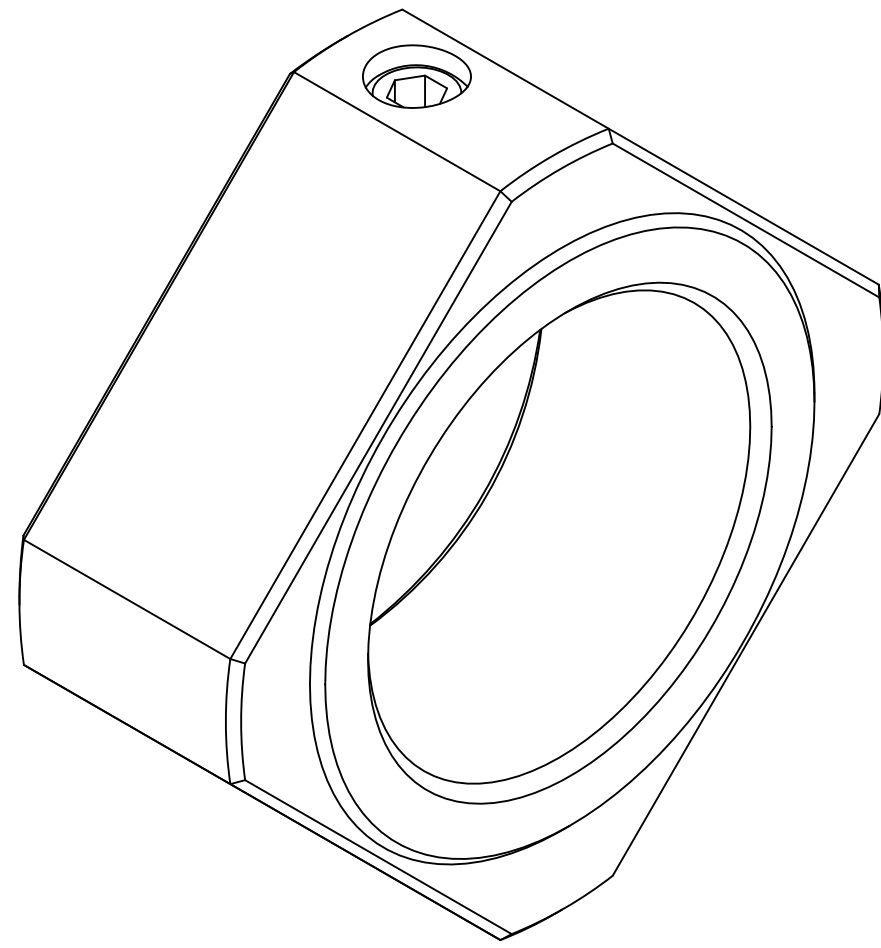

Section X-X

MARK	REASON OF REVISIONS	REVISIONER	CHECKER	DATE

HEAT TREAT

가공치수허용차		
범위	정밀급	보통급
0.5 ~ 6까지	±0.05	±0.1
6 ~ 30까지	±0.1	±0.2
30 ~ 120까지	±0.15	±0.3
120 ~ 315까지	±0.2	±0.5
315 ~ 1000까지	±0.3	±0.8
1000 ~ 2000까지	±0.5	±1.2
지시없는 모따기	R =	0.2~0.3
및 라운드	C =	0.2~0.3

APPROVED BY	
CHECKED BY	
DRAWN BY	



TITLE			
RN25 외관도			
SIZE	Dwg.NO. RN25-0000		
A	SCALE	1:1	DATE

NO	DESCRIPTION	SPECIFICATION	MAT'L	Q'TY	REMARK

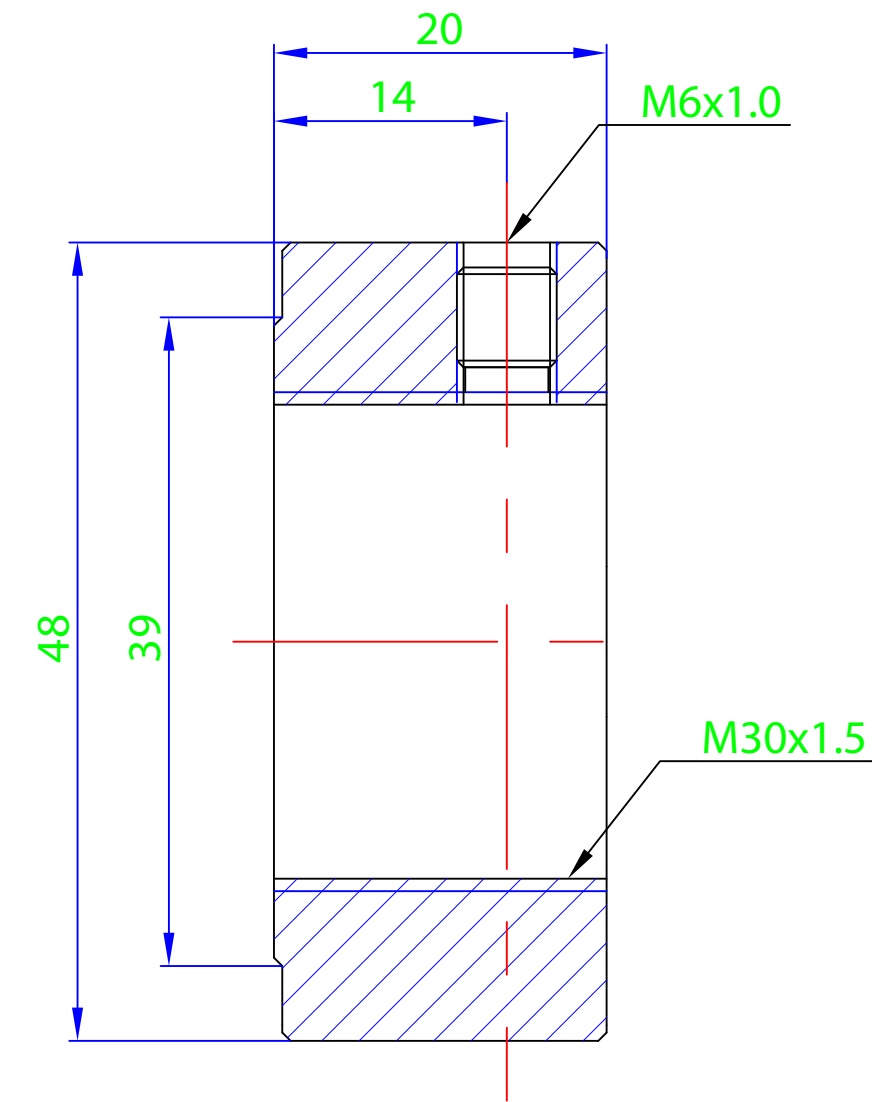
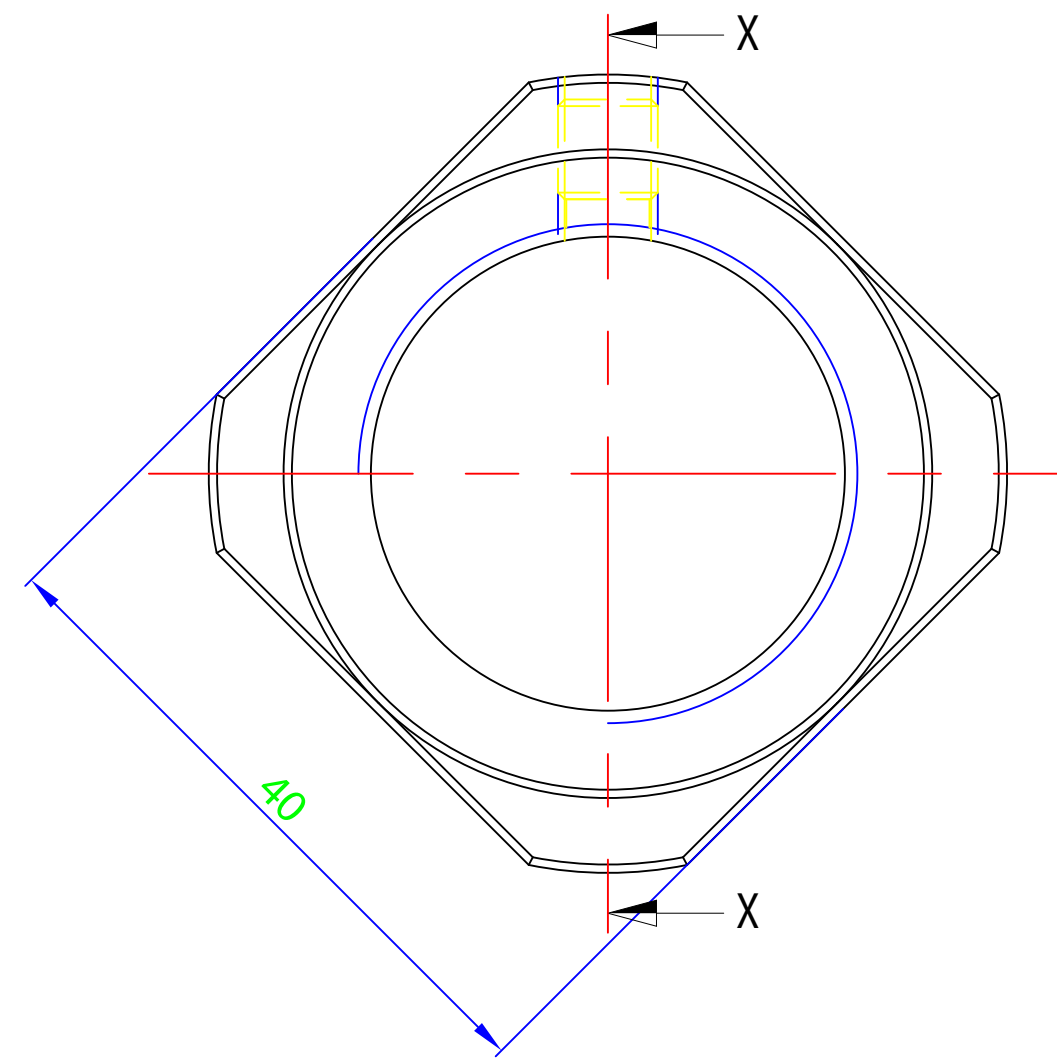
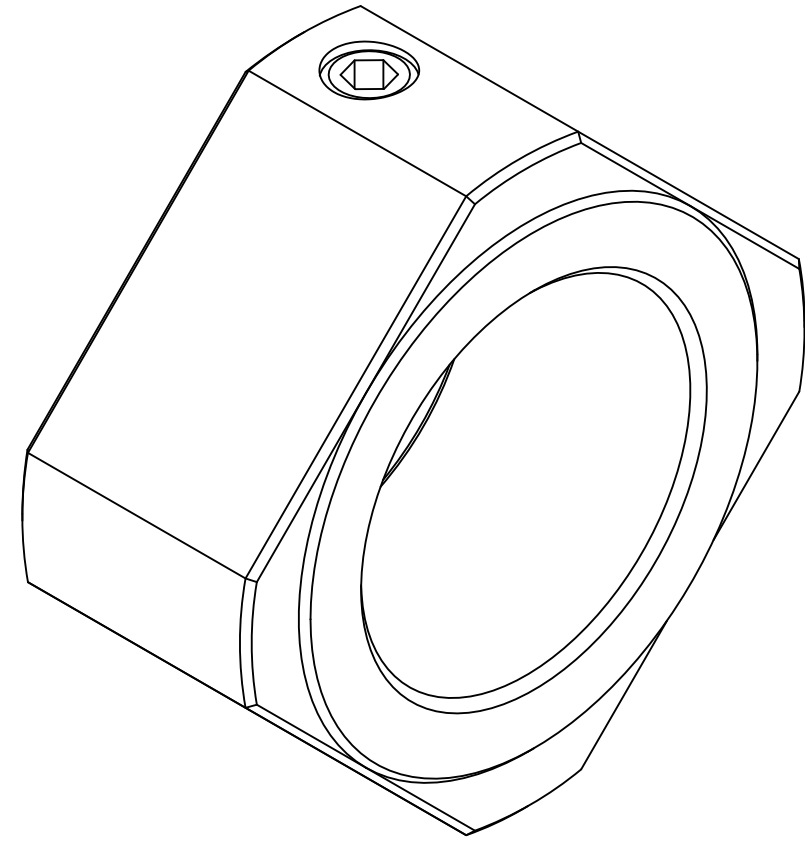

Section X-X

MARK	REASON OF REVISIONS	REVISIONER	CHECKER	DATE

HEAT TREAT	APPROVED FINISH

가공치수허용차		
범위	정밀급	보통급
0.5 ~ 6까지	±0.05	±0.1
6 ~ 30까지	±0.1	±0.2
30 ~ 120까지	±0.15	±0.3
120 ~ 315까지	±0.2	±0.5
315 ~ 1000까지	±0.3	±0.8
1000 ~ 2000까지	±0.5	±1.2
지시없는 모따기 및 라운드	R = 0.2~0.3	C = 0.2~0.3

APPROVED BY	
CHECKED BY	
DRAWN BY	

TITLE			
RN30 외관도			
SIZE	Dwg.NO. RN30-0000		
A	SCALE	1:1	DATE



NO	DESCRIPTION	SPECIFICATION	MAT'L	Q'TY	REMARK

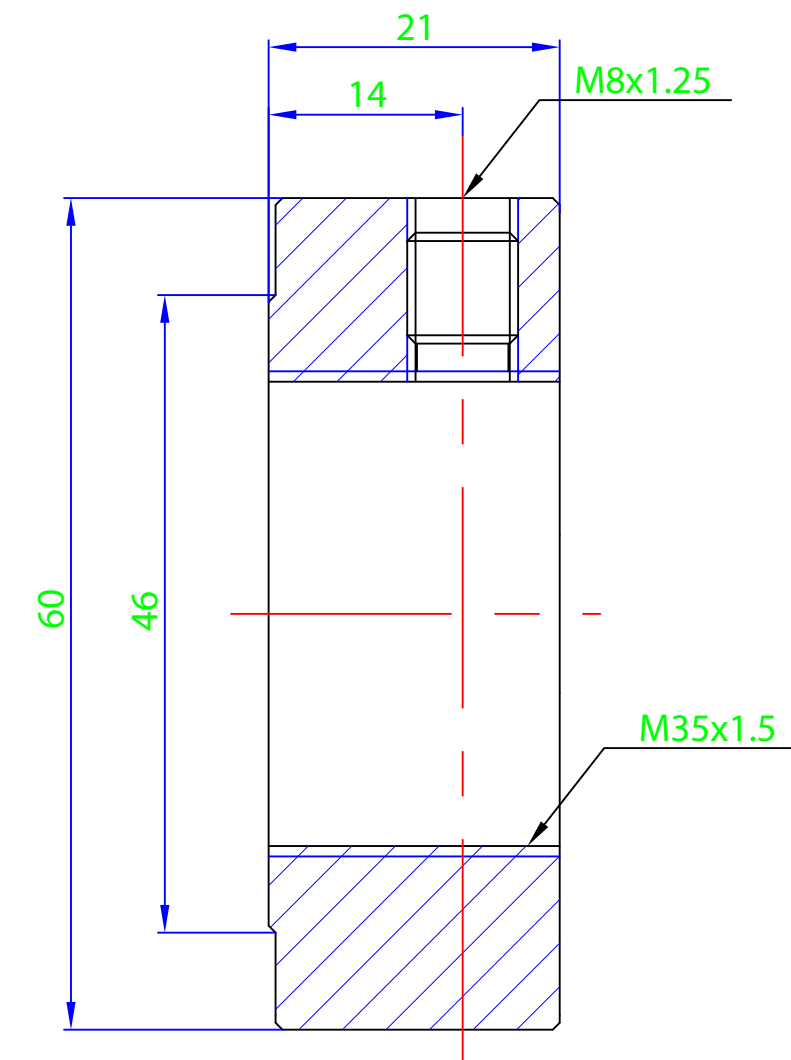
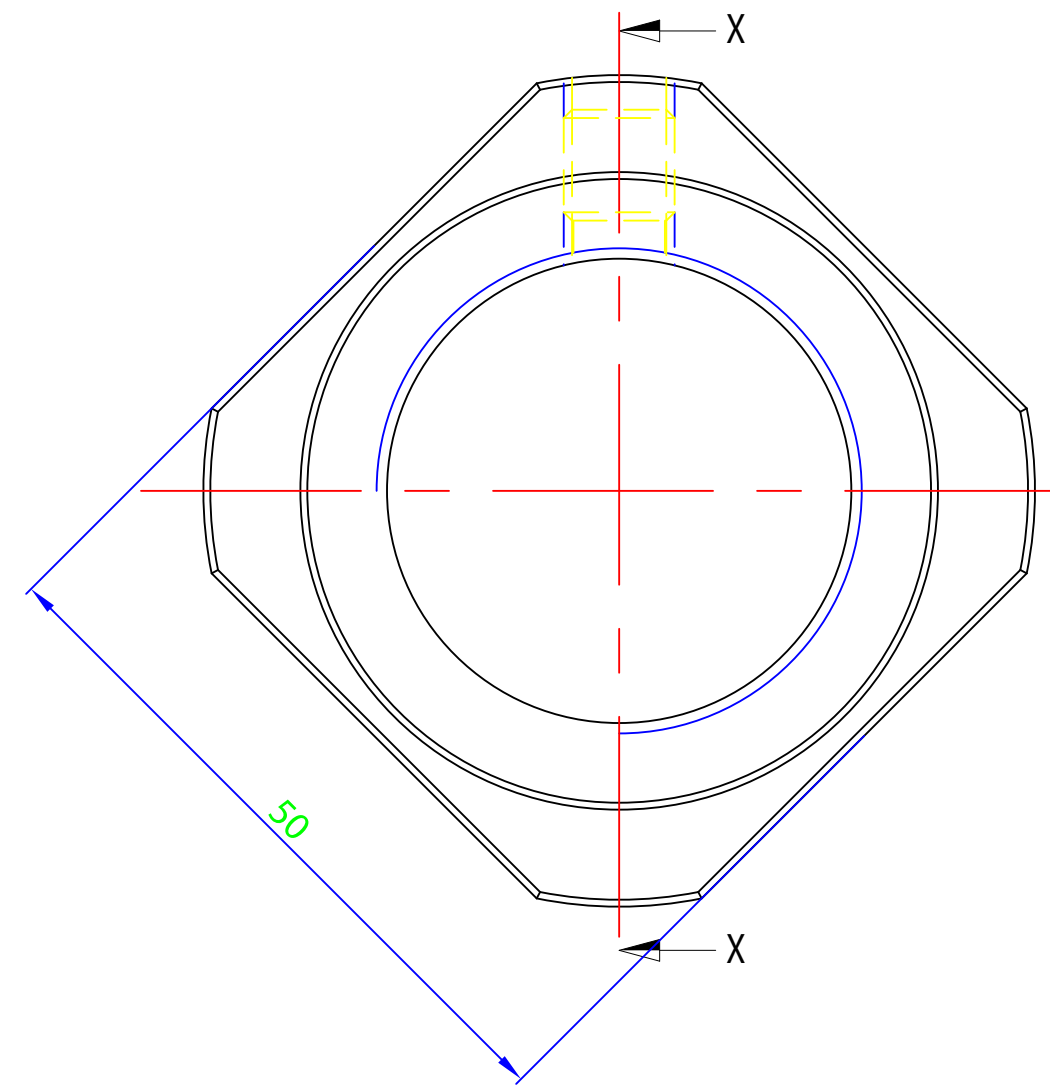
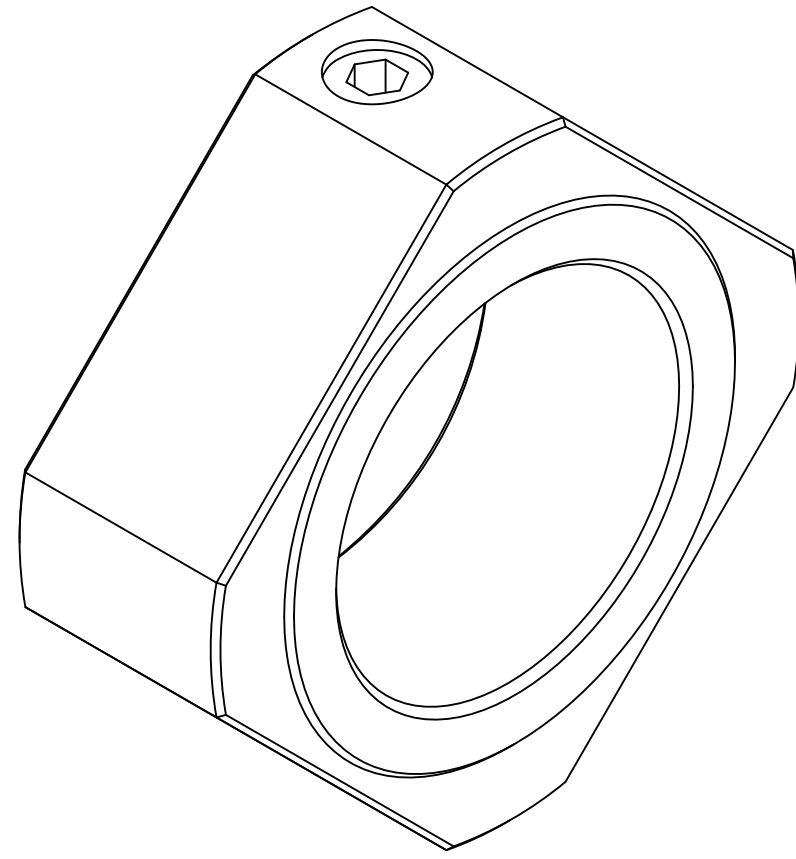

Section X-X

MARK	REASON OF REVISIONS	REVISIONER	CHECKER	DATE

REVISION

가공치수허용차		
범위	정밀급	보통급
0.5 ~ 6까지	±0.05	±0.1
6 ~ 30까지	±0.1	±0.2
30 ~ 120까지	±0.15	±0.3
120 ~ 315까지	±0.2	±0.5
315 ~ 1000까지	±0.3	±0.8
1000 ~ 2000까지	±0.5	±1.2
지시없는 모따기	R =	0.2~0.3
및 라운드	C =	0.2~0.3

APPROVED BY
CHECKED BY
DRAWN BY

SUNGIL

TITLE			
RN35 외관도			
SIZE	Dwg.NO. RN35-0000		
A	SCALE	1:1	DATE

NO	DESCRIPTION	SPECIFICATION	MAT'L	Q'TY	REMARK

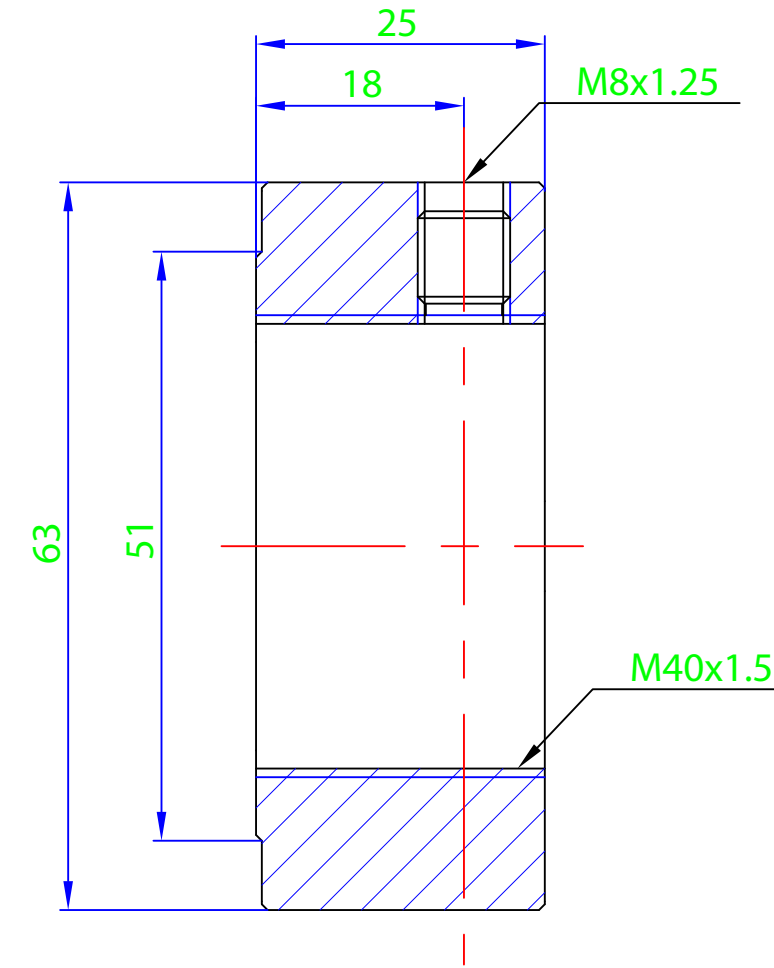
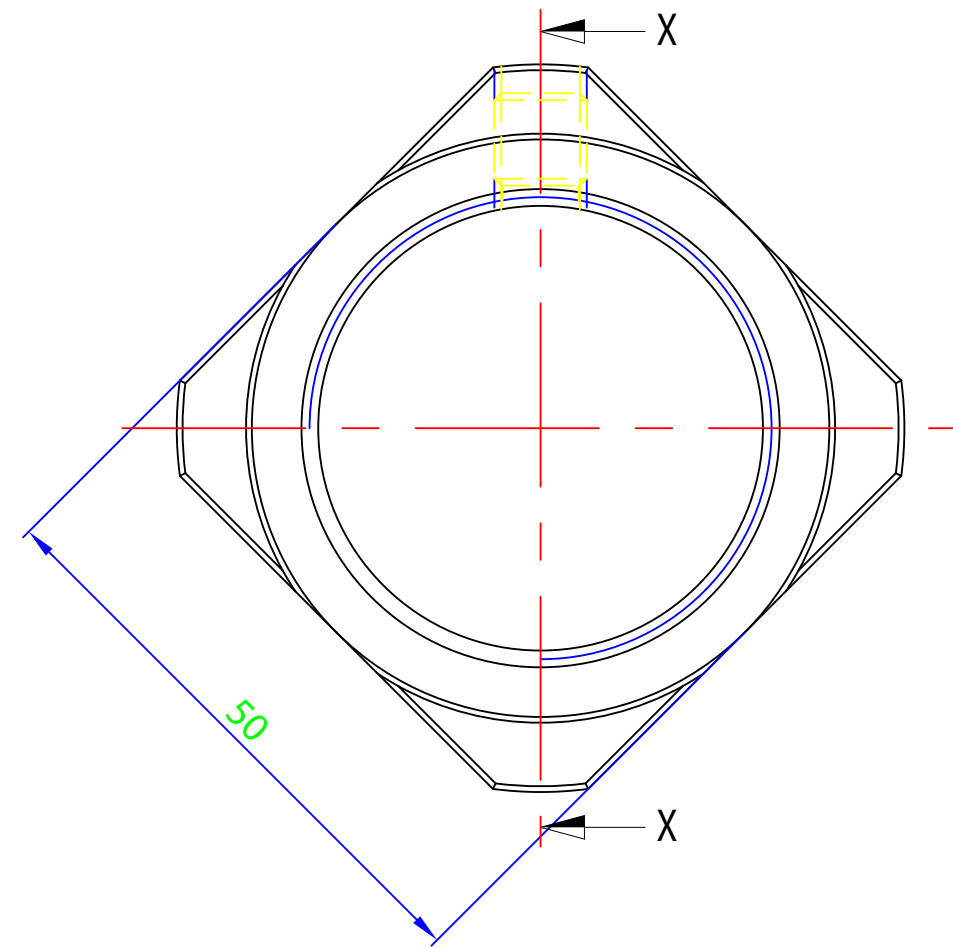
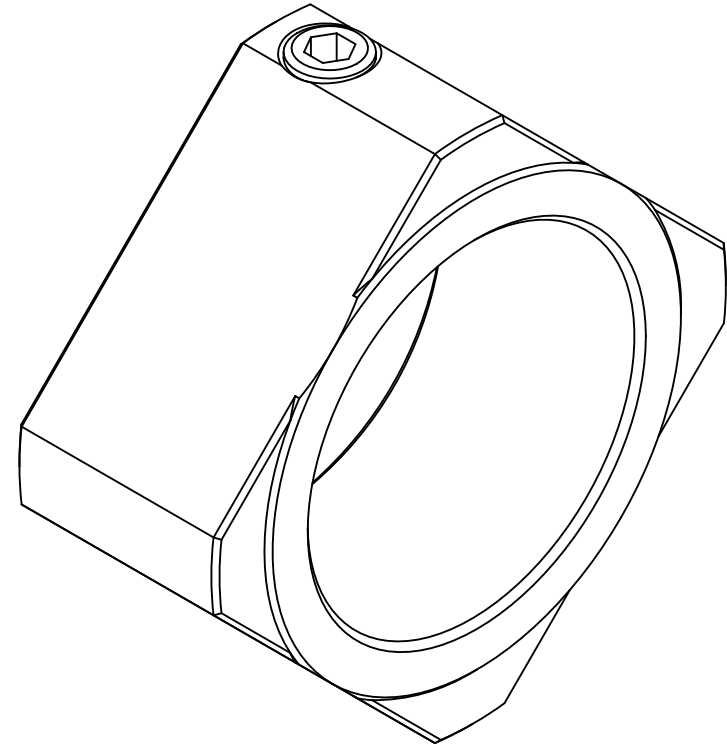

Section X-X

MARK	REASON OF REVISIONS	REVISIONER	CHECKER	DATE

REVISION

가공치수허용차		
범위	정밀급	보통급
0.5 ~ 6까지	±0.05	±0.1
6 ~ 30까지	±0.1	±0.2
30 ~ 120까지	±0.15	±0.3
120 ~ 315까지	±0.2	±0.5
315 ~ 1000까지	±0.3	±0.8
1000 ~ 2000까지	±0.5	±1.2
지시없는 모따기 및 라운드	R = 0.2~0.3	C = 0.2~0.3

APPROVED BY
CHECKED BY
DRAWN BY

TITLE			
RN40 외관도			
SIZE	Dwg.NO. RN40-0000		
A	SCALE	1:1	DATE