

NO	DESCRIPTION	SPECIFICATION	MAT'L	Q'TY	REMARK

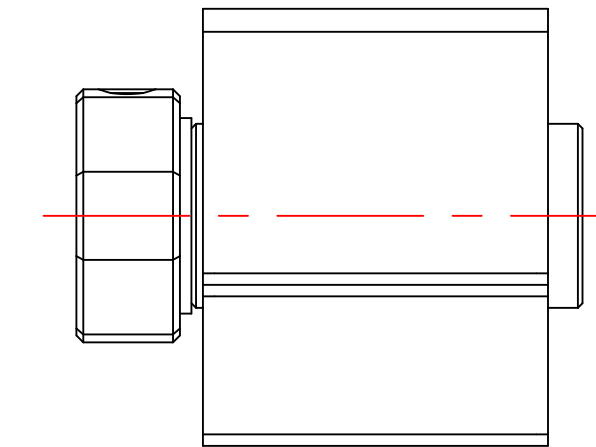
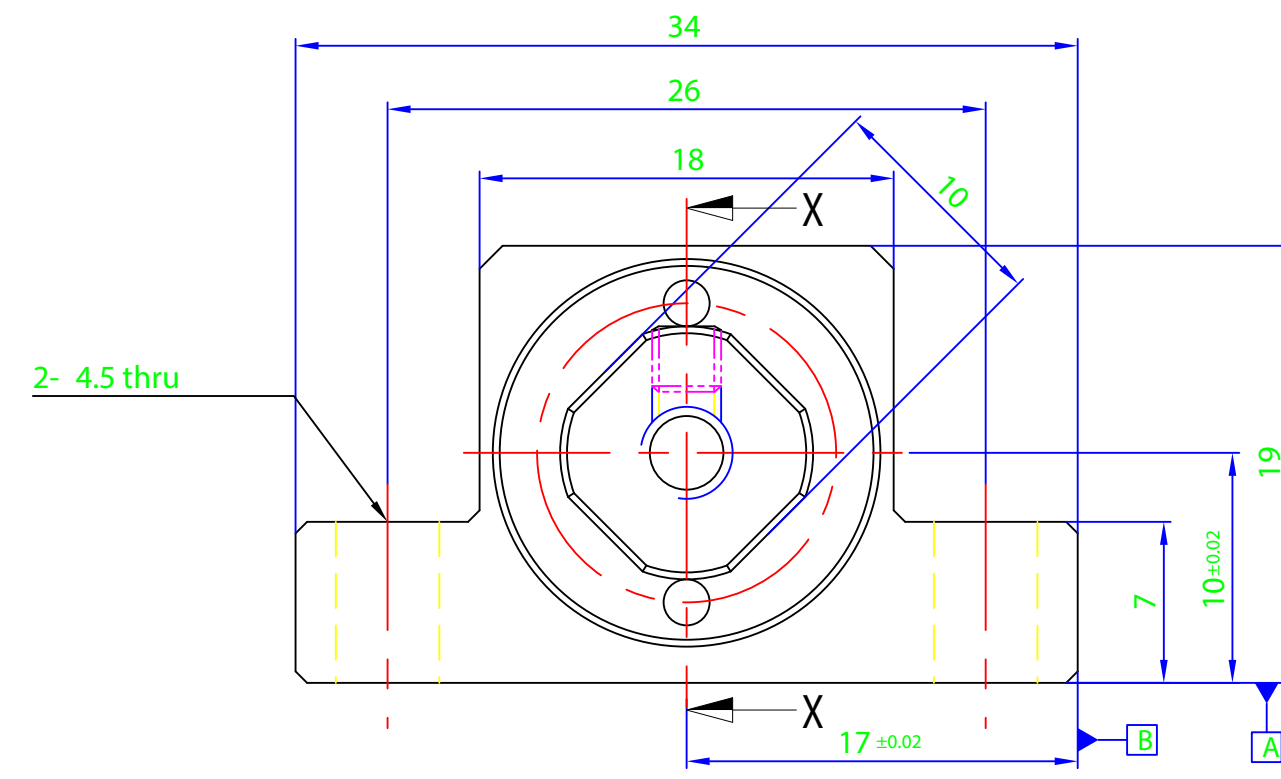
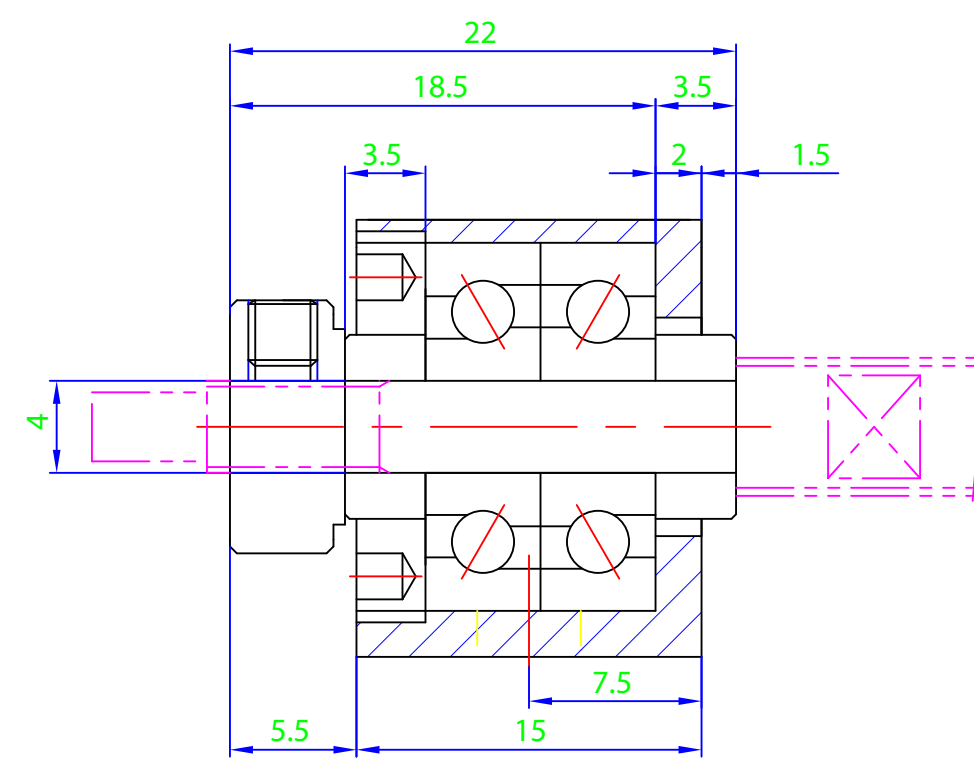
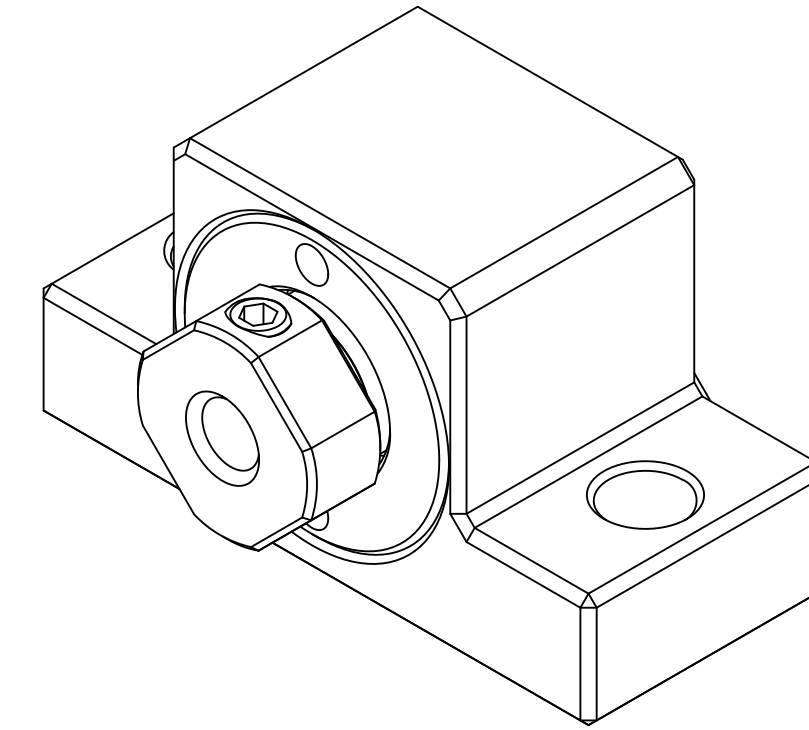
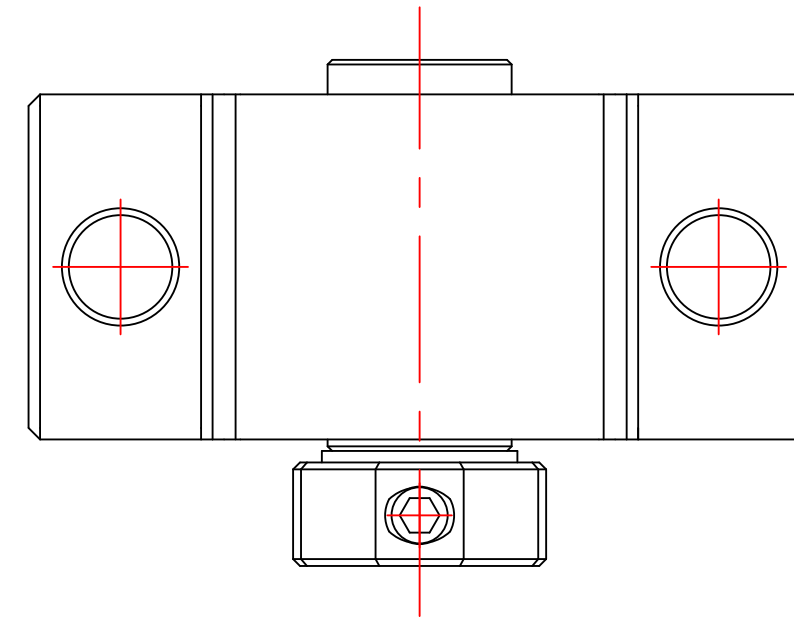

Section X-X

MARK	REASON OF REVISIONS	REVISIONER	CHECKER	DATE

가공치수허용차		
범위	정밀급	보통급
0.5 ~ 6까지	±0.05	±0.1
6 ~ 30까지	±0.1	±0.2
30 ~ 120까지	±0.15	±0.3
120 ~ 315까지	±0.2	±0.5
315 ~ 1000까지	±0.3	±0.8
1000 ~ 2000까지	±0.5	±1.2
지시없는 모따기	R =	0.2~0.3
빛 라운드	C =	0.2~0.3

APPROVED BY _____
 CHECKED BY _____
 DRAWN BY _____

SUNGIL

TITLE			
EK4 외관도			
SIZE	Dwg.NO. EK4-0000		
A	SCALE	1:1	DATE

기호 N.O.	수정일자 DATE	사유 CONTENT	수정 REV BY	확인 CH'ED BY
△				

THIS DRAWING IS PROPRIETARY TO SUNGIL
 NO PART OF THIS DRAWING MAY BE REPRODUCED
 WITHOUT THE PERMISSION OF SUNGIL.
 허가없이 복사할 수 없음.

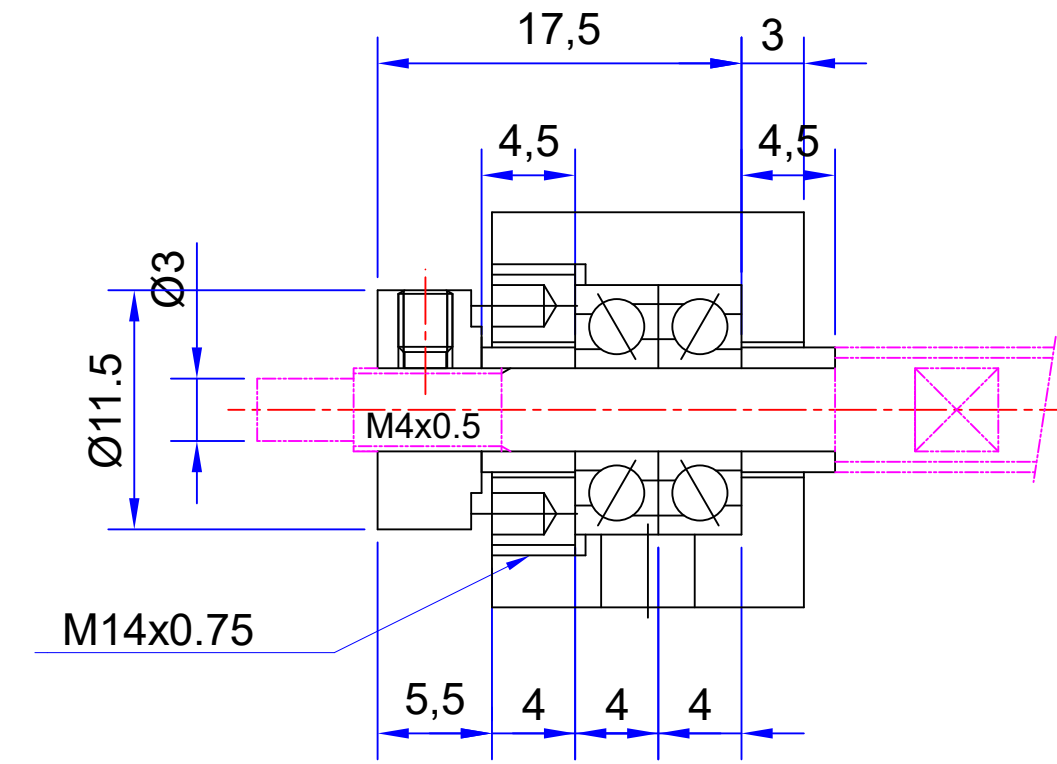
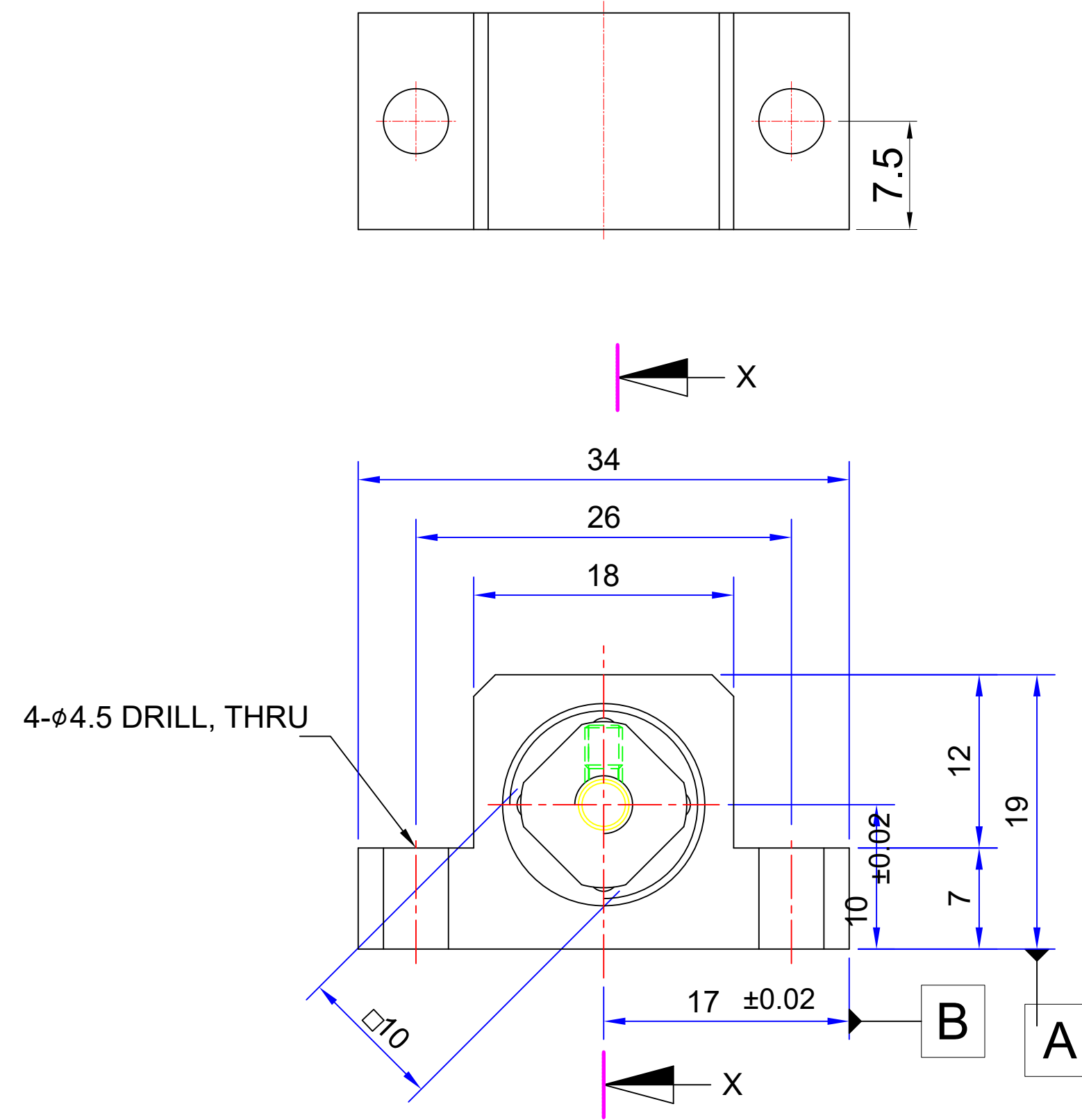

SECTION X-X

가공치수허용치			0000	전체조립도	1				
범위	정밀급	보통급	품번 N.O.	품명 DESCRIPTION	수량 Q'TY	재질 MT'L	PER ONE Q'TY	규격 DIMENSION	비고 REMARKS
0.5 ~ 6 까지	±0.05	±0.1					총량 TOTAL		
6 ~ 30 까지	±0.1	±0.2	적용 TITLE				도명 NAME		
30 ~ 120 까지	±0.15	±0.3	서포트유니트				EK4-P5		
120 ~ 315 까지	±0.2	±0.5	척도 SCALE	1/2	투상법 PROJECTION	제3각법 3RD ANGLE	가공공차 TOLERANCE	도번 DWG. NO	SU_EK4-P5_0000
315 ~ 1000 까지	±0.3	±0.8	제도 DRAW BY	설계 DESIGNED BY	검도 CHECK BY	과장 RECH'D BY	심사 RECH'D BY	승인 APP'D BY	관련도번 REF. NO
1000 ~ 2000 까지	±0.5	±1.2	홍유식						
지시없는 모따기 및 라운드	R =	C =	2011.3.1				SUNGIL MACHINERY CO., LTD.		

NO	DESCRIPTION	SPECIFICATION	MAT'L	Q'TY	REMARK

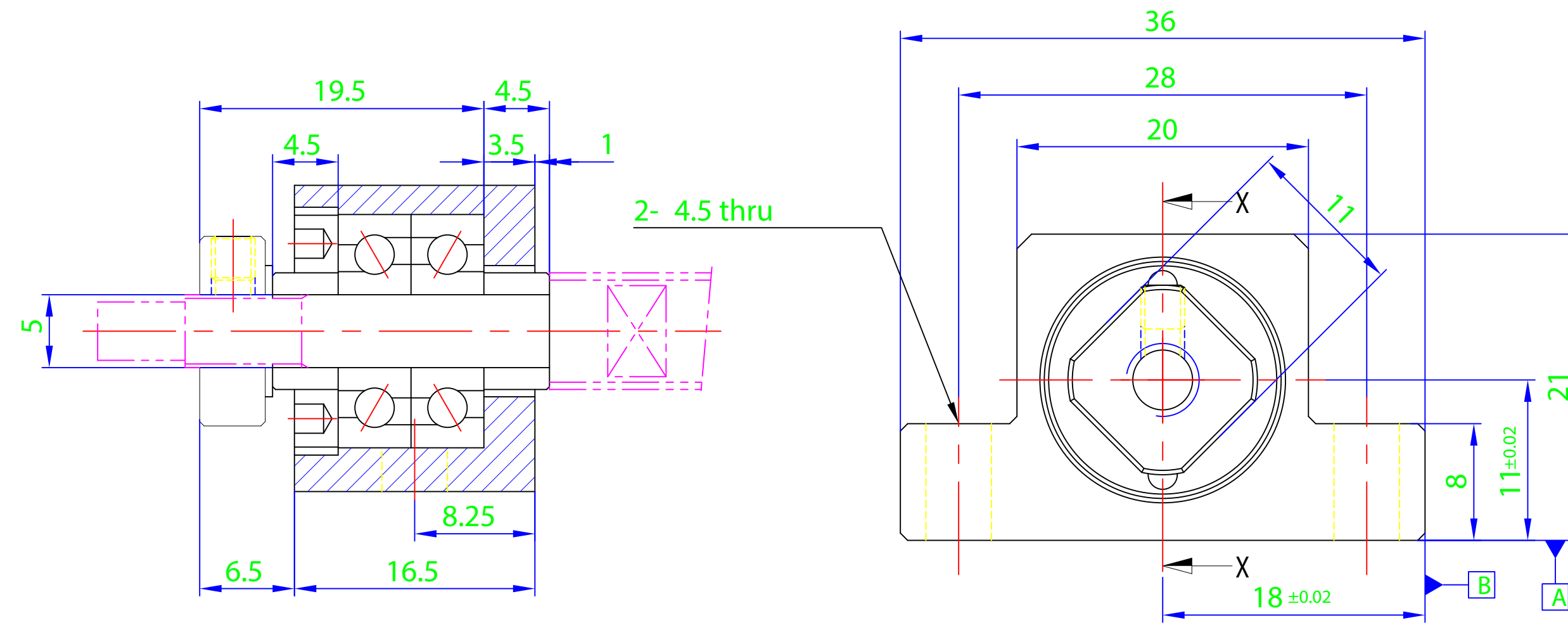
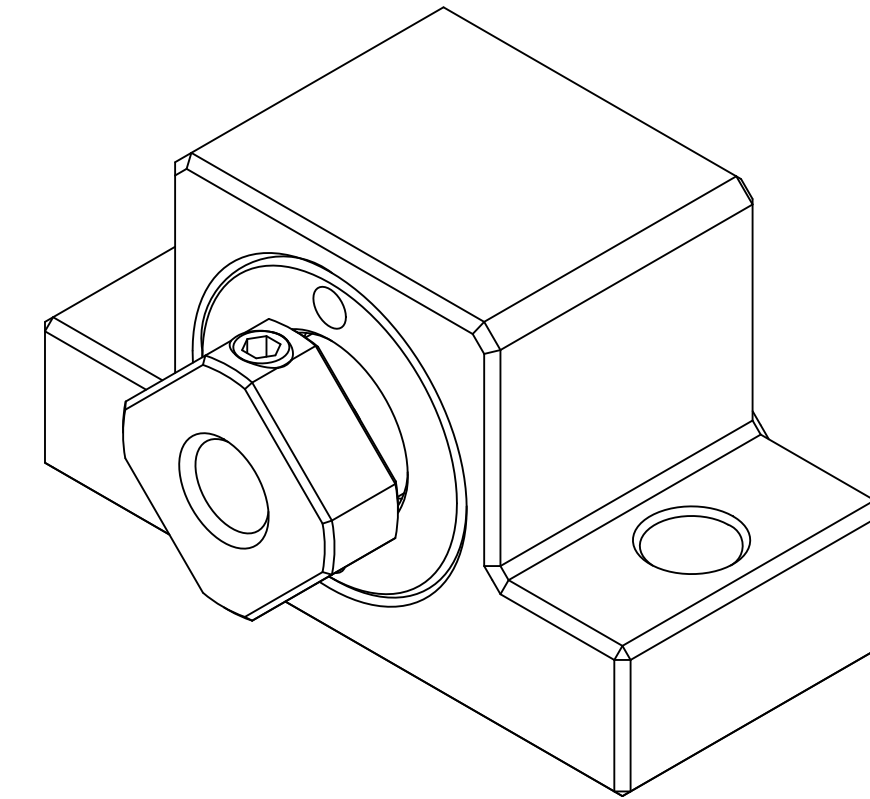
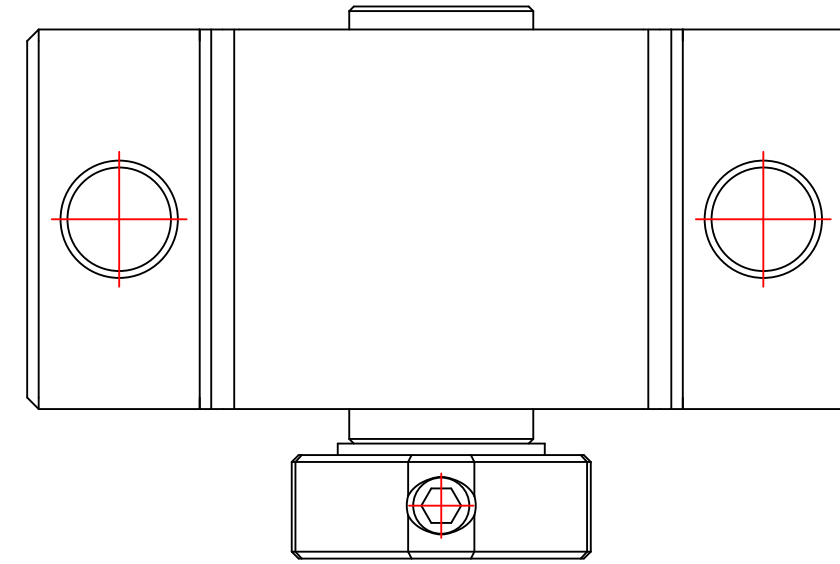

Section X-X

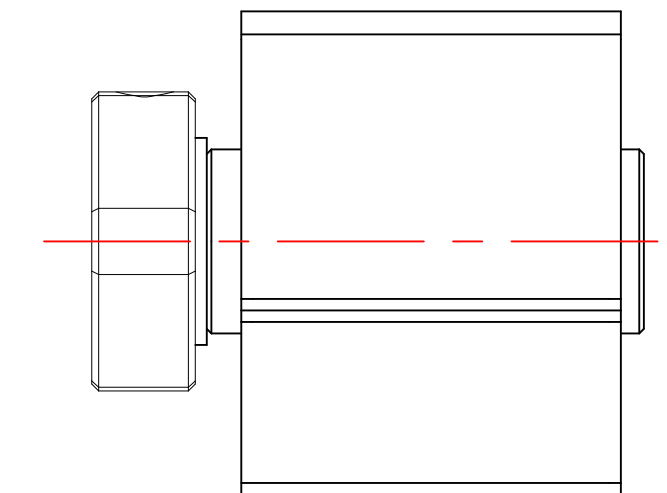

가공치수허용차		
범위	정밀급	보통급
0.5 ~ 6까지	±0.05	±0.1
6 ~ 30까지	±0.1	±0.2
30 ~ 120까지	±0.15	±0.3
120 ~ 315까지	±0.2	±0.5
315 ~ 1000까지	±0.3	±0.8
1000 ~ 2000까지	±0.5	±1.2
지시없는 모따기	R =	0.2~0.3
빛 라운드	C =	0.2~0.3

APPROVED BY
 CHECKED BY
 DRAWN BY
SUNGIL

TITLE			
EK5 외관도			
SIZE	Dwg.NO. EK5-0000		
A	SCALE	1:1	DATE

MARK	REASON OF REVISIONS	REVISIONER	CHECKER	DATE	HEAT TREAT	APPROVED FINISH
REVISION						

기호 N.O.	수정일자 DATE	사유 CONTENT	수정 REV BY	확인 CHECKED BY
△				

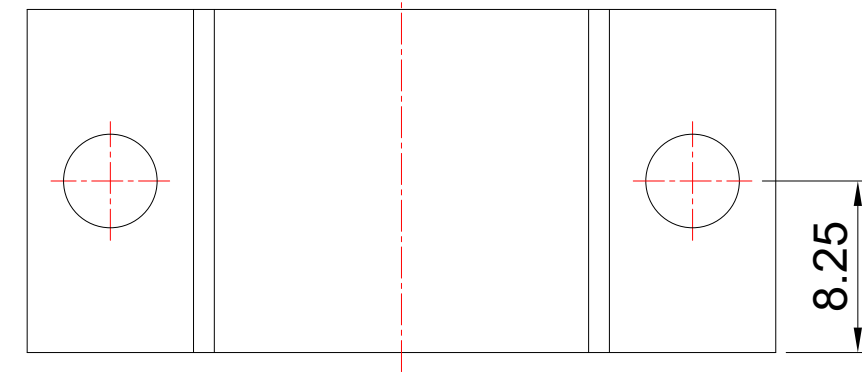

2-φX DRILL, THRU

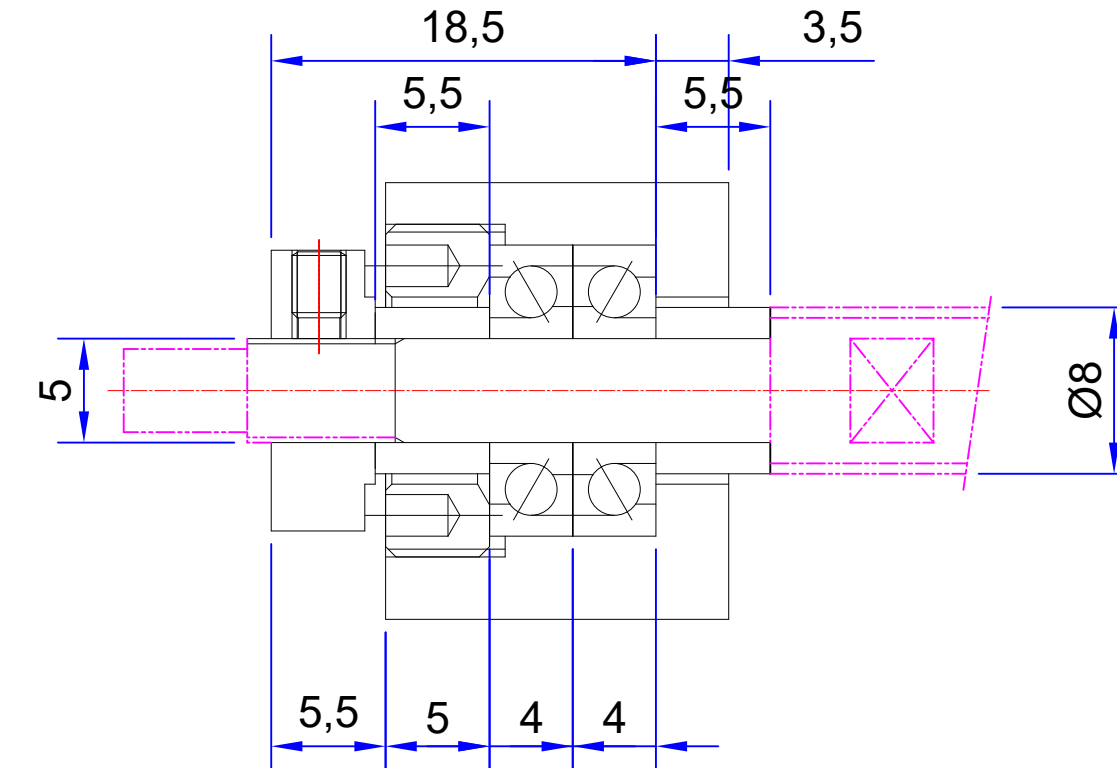
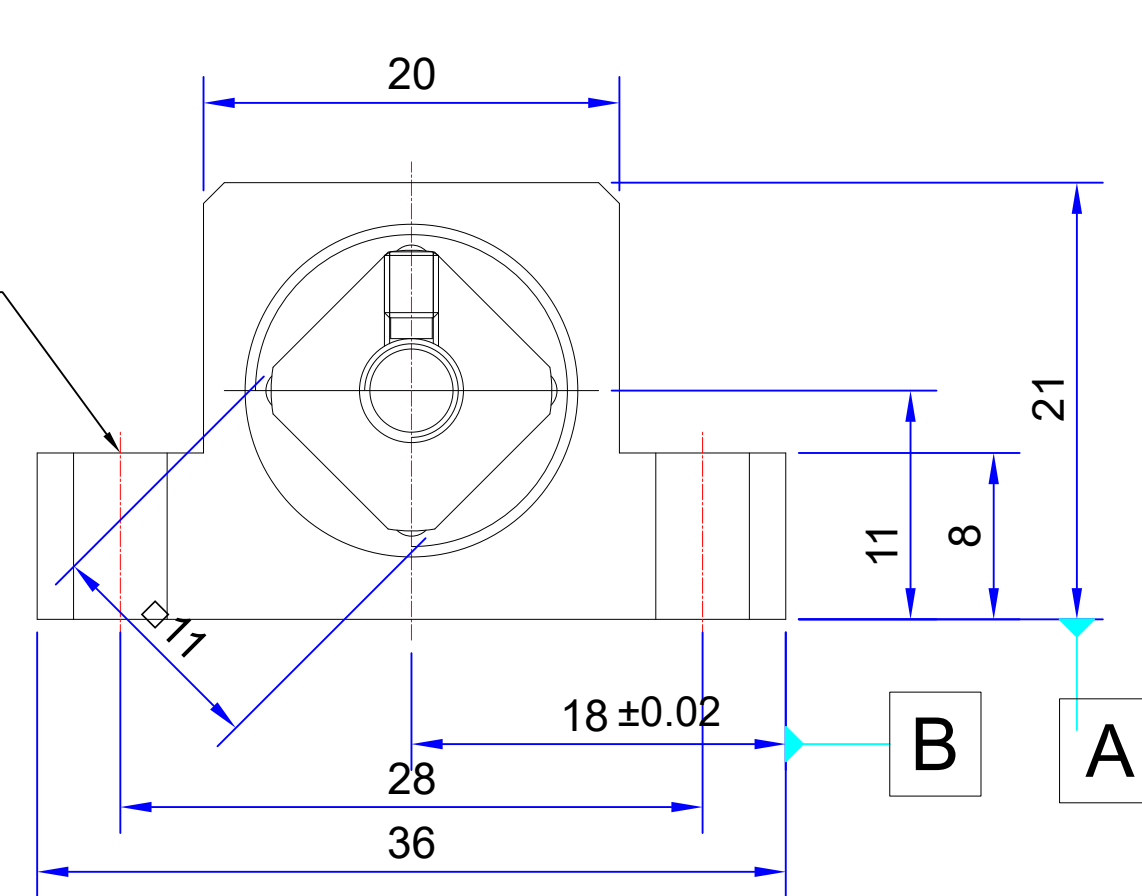

가공치수허용치			0000	전체조립도	1					
범위	정밀급	보통급	품번 N.O.	품명 DESCRIPTION	수량 Q'TY	재질 M'T'L	PER ONE 총량 TOTAL	Q'TY	규격 DIMENSION	비고 REMARKS
0.5 ~ 6 까지	±0.05	±0.1	적용	서포트유니트					도명 NAME EK5-P5	
6 ~ 30 까지	±0.1	±0.2								
30 ~ 120 까지	±0.15	±0.3								
120 ~ 315 까지	±0.2	±0.5								
315 ~ 1000 까지	±0.3	±0.8	척도 SCALE	1/2	투상법 PROJECTION	제3각법 3RD ANGLE	가공공차 TOLERANCE		도번 DWG. NO	SU_EK5-P5_0000
1000 ~ 2000 까지	±0.5	±1.2	제도 DRAW BY	설계 DESIGNED BY	검도 CHECK BY	과장 RECHED BY	심사 RECHED BY	승인 APP'D BY	관련도번 REF. NO	
지시없는 모따기	R =		홍유식							
및 라운드	C =		2011.3.1							

NO	DESCRIPTION	SPECIFICATION	MAT'L	Q'TY	REMARK

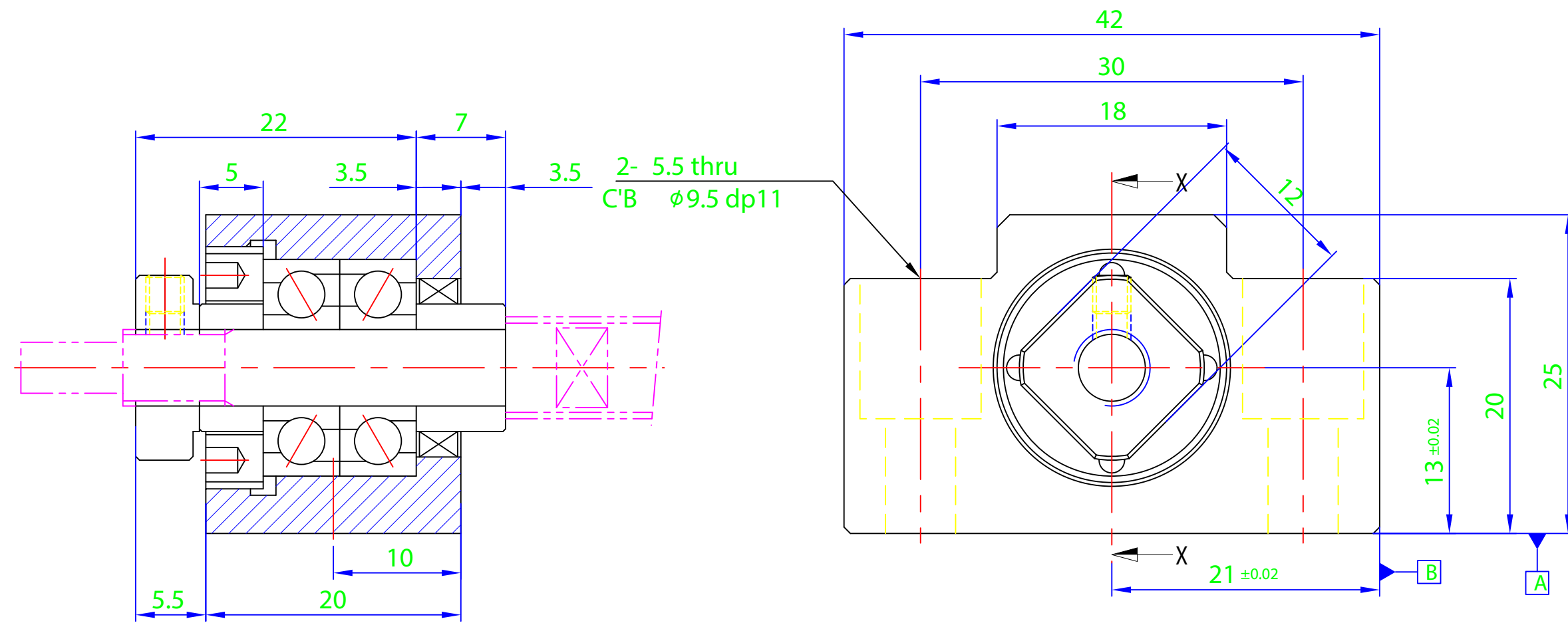
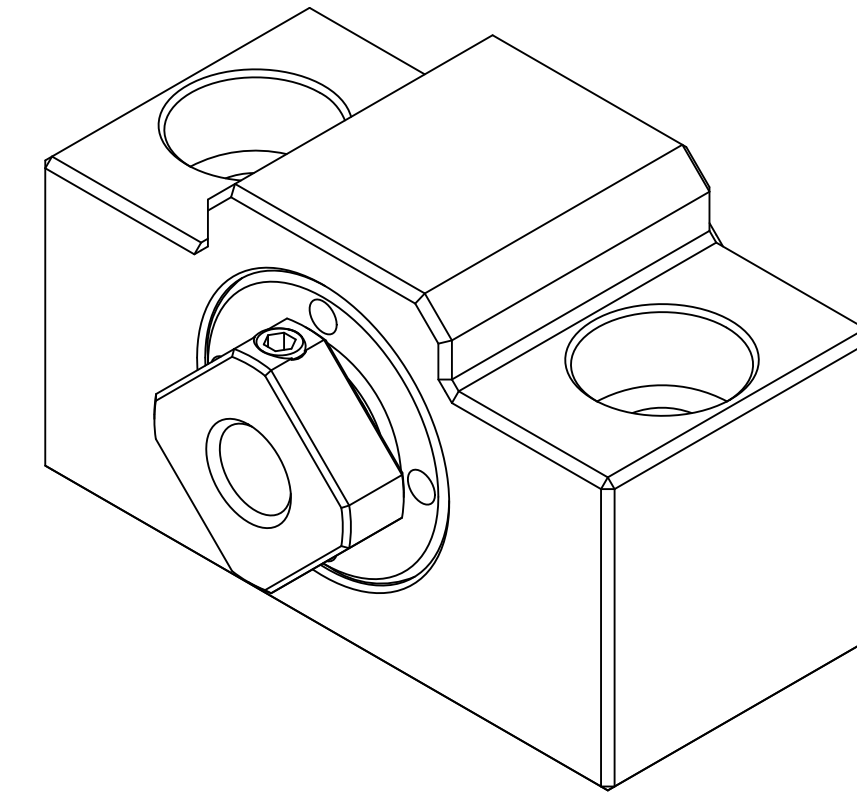
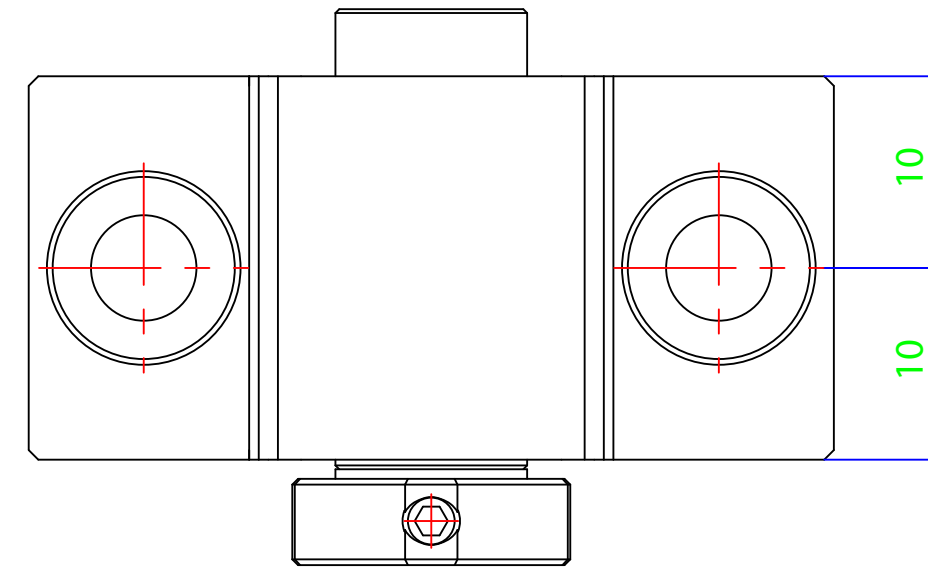

Section X-X

MARK	REASON OF REVISIONS	REVISIONER	CHECKER	DATE

HEAT TREAT

가공치수허용차		
범위	정밀급	보통급
0.5 ~ 6까지	±0.05	±0.1
6 ~ 30까지	±0.1	±0.2
30 ~ 120까지	±0.15	±0.3
120 ~ 315까지	±0.2	±0.5
315 ~ 1000까지	±0.3	±0.8
1000 ~ 2000까지	±0.5	±1.2
지시없는 모따기 및 라운드	R = 0.2~0.3	C = 0.2~0.3

APPROVED BY _____
 CHECKED BY _____
 DRAWN BY _____

SUNGIL

TITLE			
EK6 외관도			
SIZE	Dwg.NO. EK6-0000		
A	SCALE	1:1	DATE

NO	DESCRIPTION	SPECIFICATION	MAT'L	Q'TY	REMARK

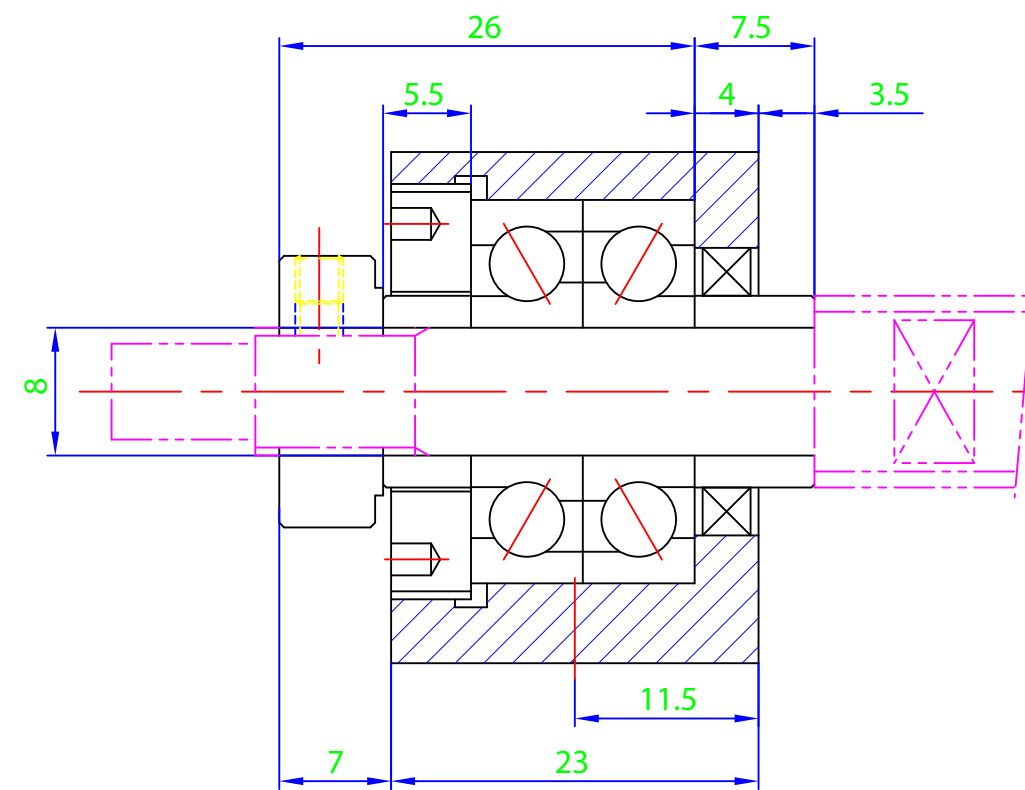
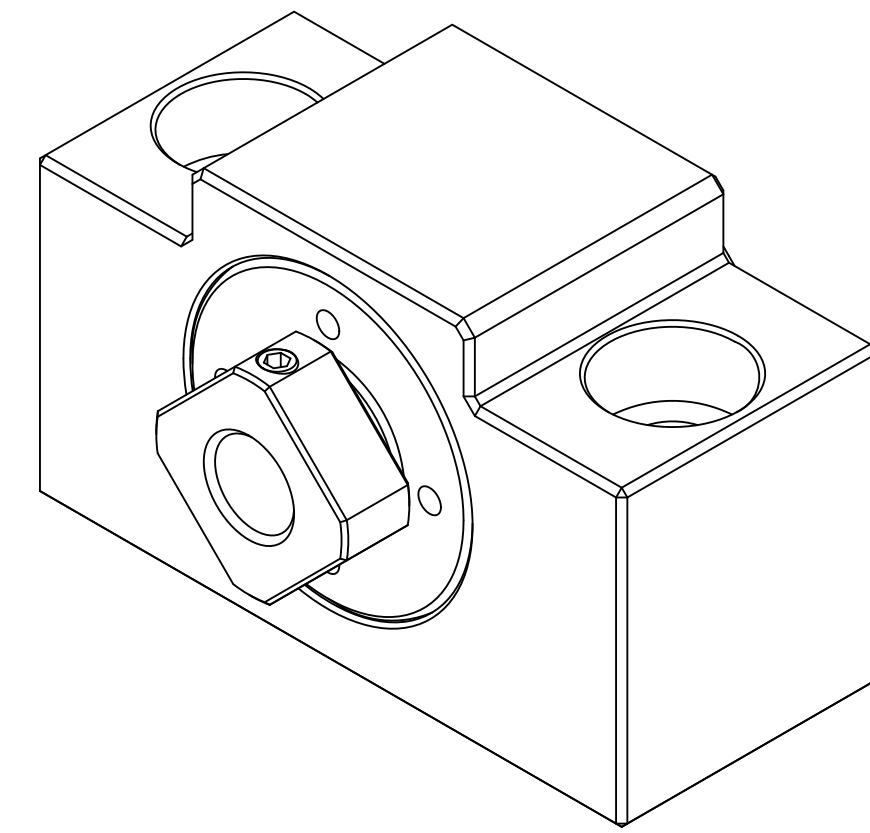
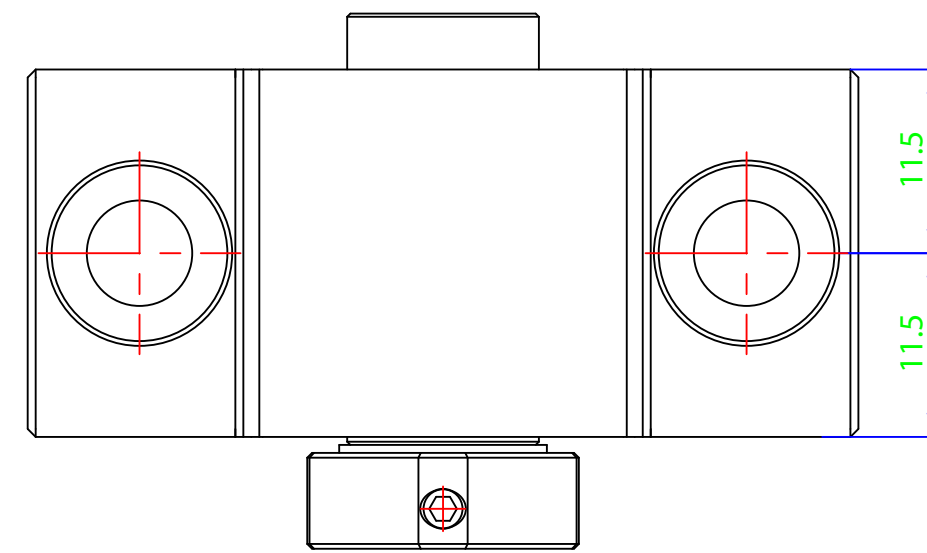

Section X-X

2- 6.6 thru
C'B $\phi 11$ dp12

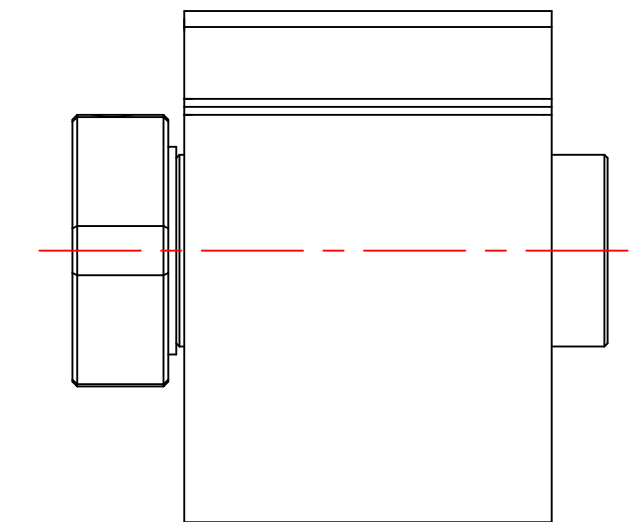
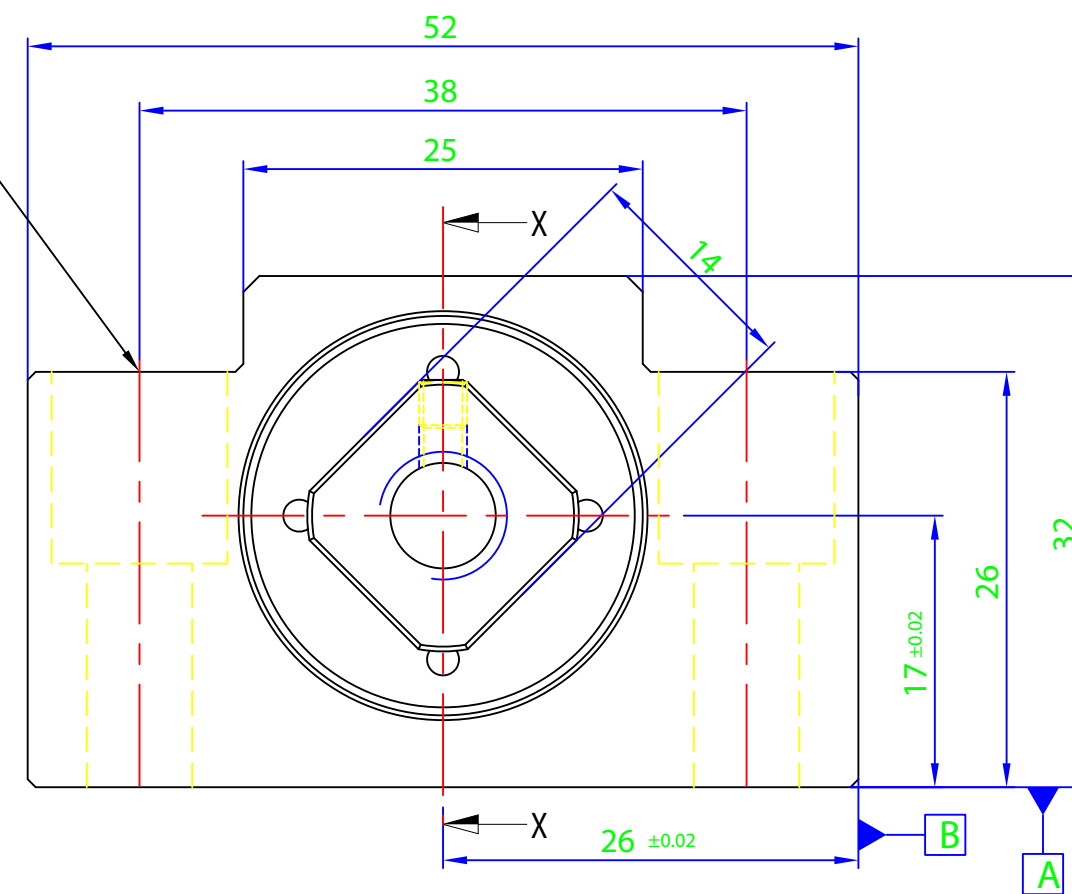

가공치수허용차		
범위	정밀급	보통급
0.5 ~ 6까지	±0.05	±0.1
6 ~ 30까지	±0.1	±0.2
30 ~ 120까지	±0.15	±0.3
120 ~ 315까지	±0.2	±0.5
315 ~ 1000까지	±0.3	±0.8
1000 ~ 2000까지	±0.5	±1.2
지시없는 모따기 및 라운드	R = 0.2~0.3	C = 0.2~0.3

APPROVED BY _____
 CHECKED BY _____
 DRAWN BY _____

SUNGIL

TITLE			
EK8 외관도			
SIZE	Dwg.NO. EK8-0000		
A	SCALE	1:1	DATE

MARK	REASON OF REVISIONS	REVISIONER	CHECKER	DATE

REVISION

NO	DESCRIPTION	SPECIFICATION	MAT'L	Q'TY	REMARK

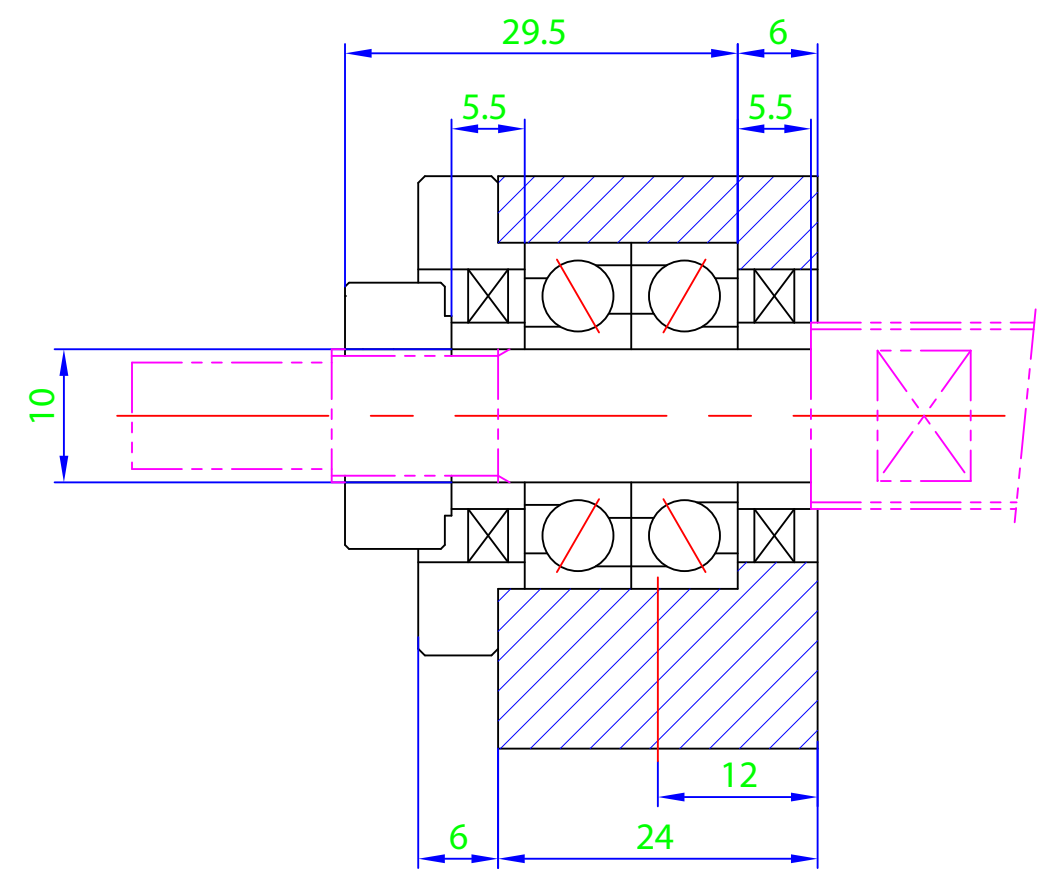
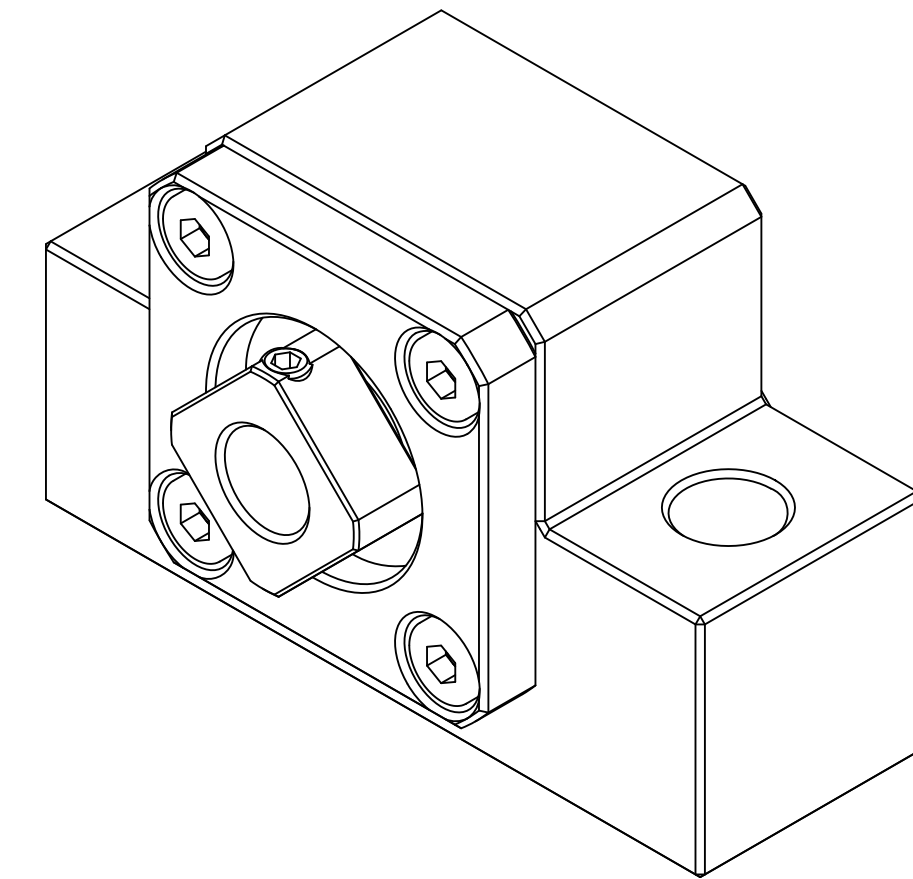
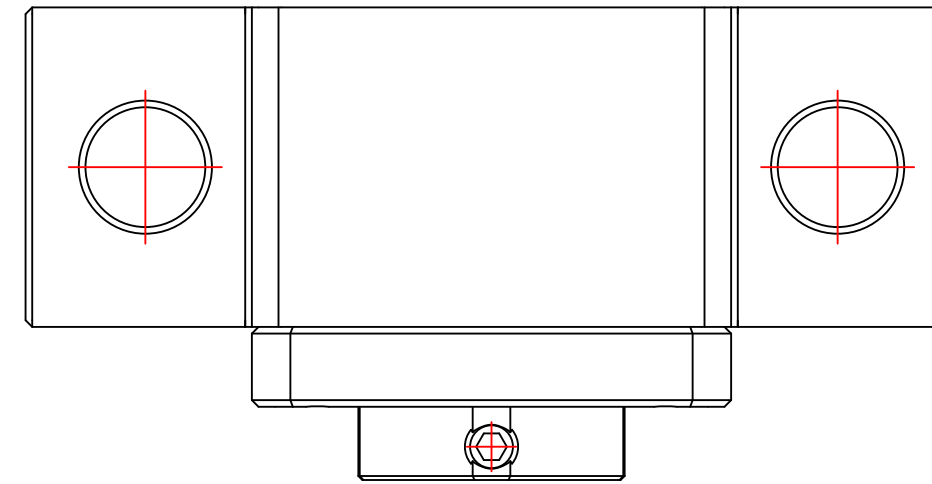

Section X-X

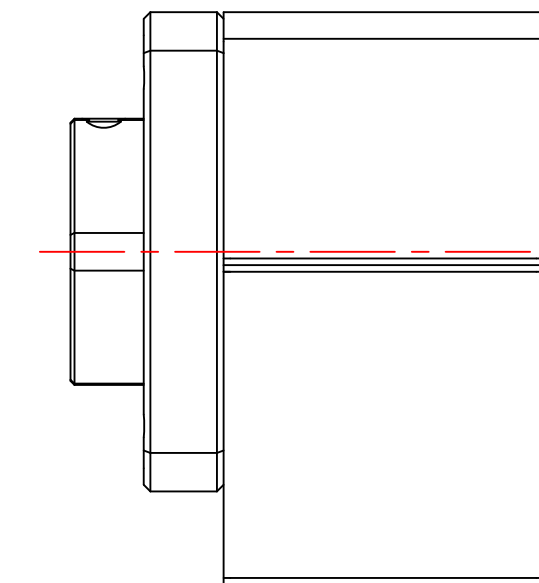
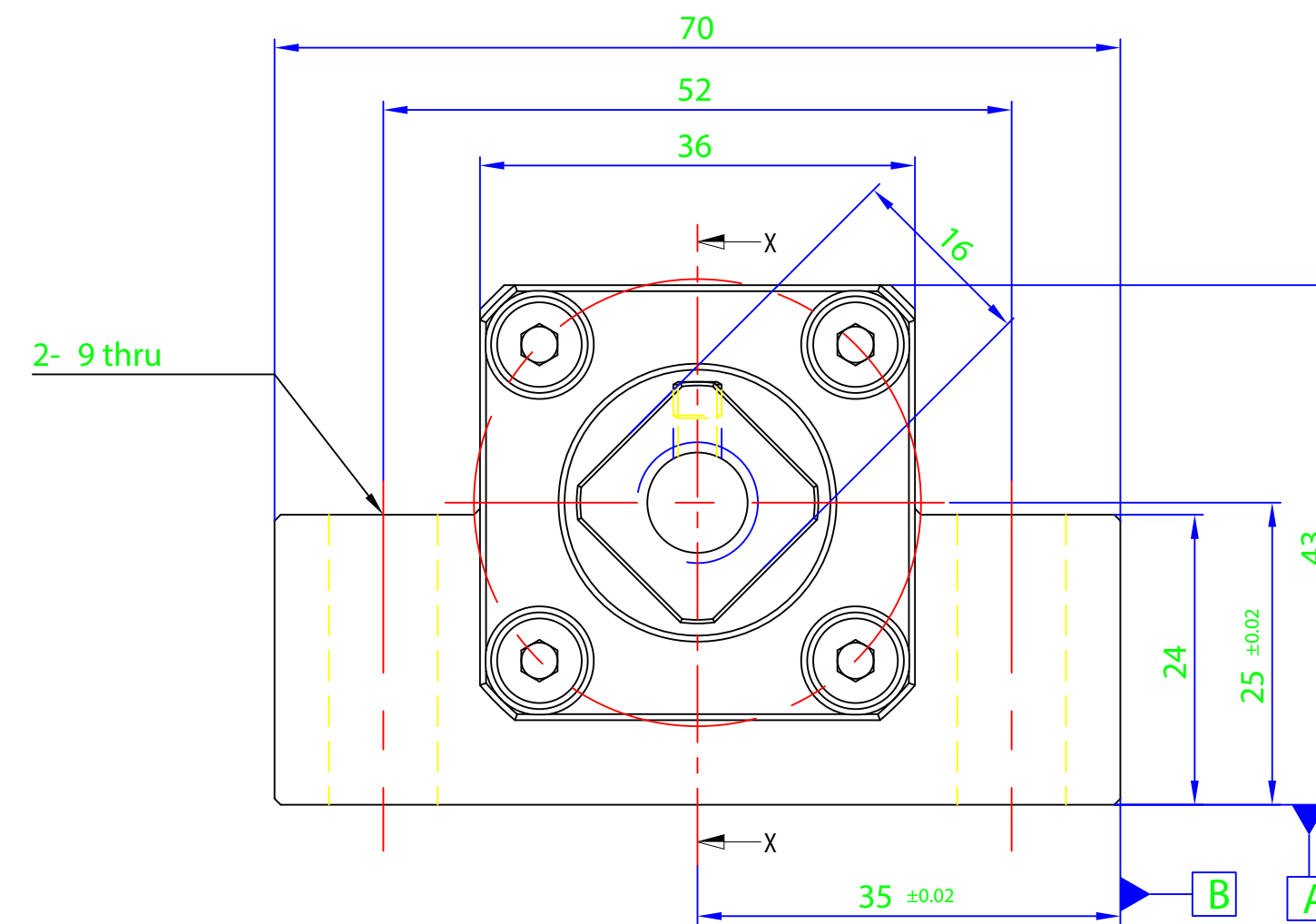

가공치수허용차		
범위	정밀급	보통급
0.5 ~ 6까지	±0.05	±0.1
6 ~ 30까지	±0.1	±0.2
30 ~ 120까지	±0.15	±0.3
120 ~ 315까지	±0.2	±0.5
315 ~ 1000까지	±0.3	±0.8
1000 ~ 2000까지	±0.5	±1.2
지시없는 모따기	R =	0.2~0.3
및 라운드	C =	0.2~0.3

APPROVED BY	
CHECKED BY	
DRAWN BY	

TITLE	EK10 외관도		
SIZE	A		

MARK	REASON OF REVISIONS	REVISIONER	CHECKER	DATE

HEAT TREAT	
APPROVED FINISH	



Dwg.NO.	EK10-0000		
SCALE	1:1	DATE	

NO	DESCRIPTION	SPECIFICATION	MAT'L	Q'TY	REMARK

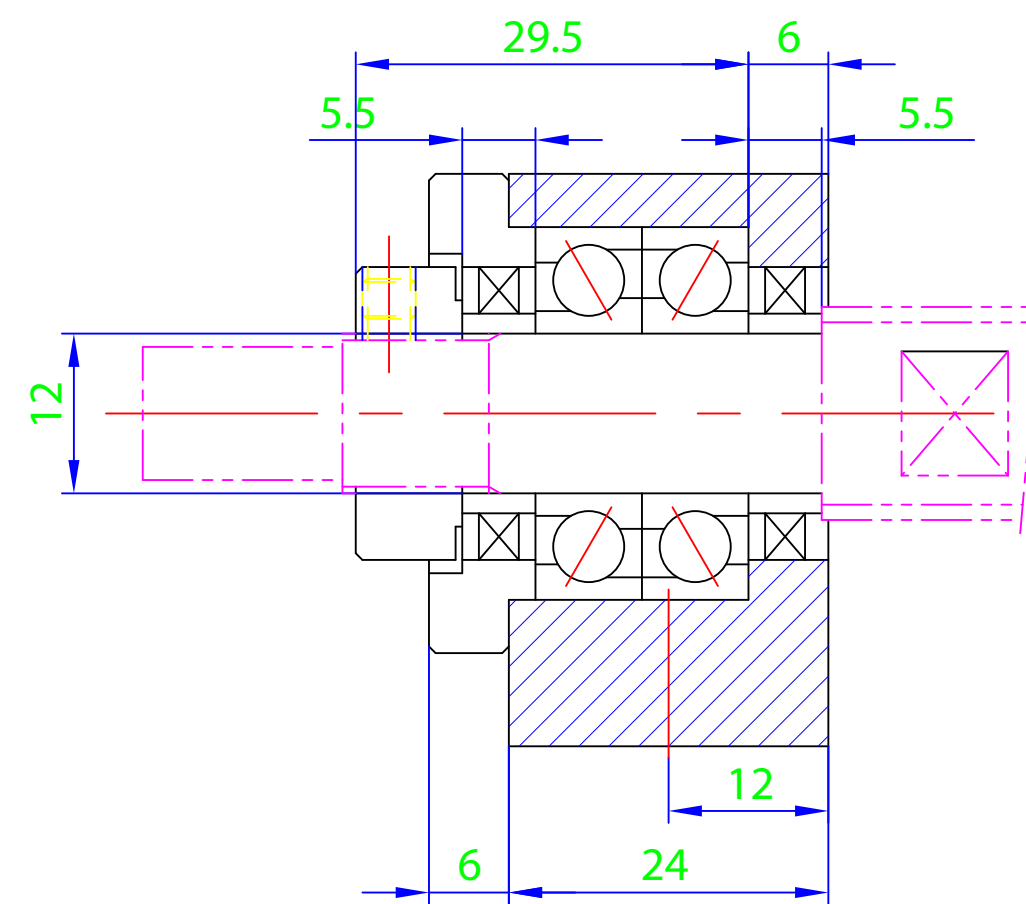
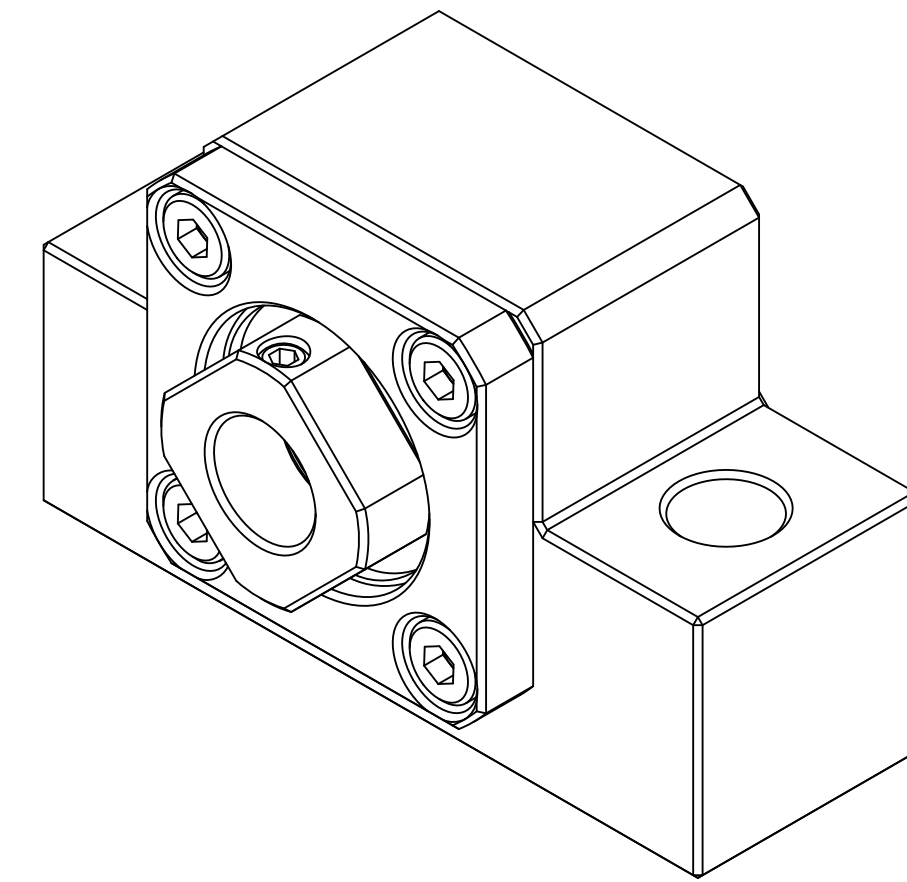
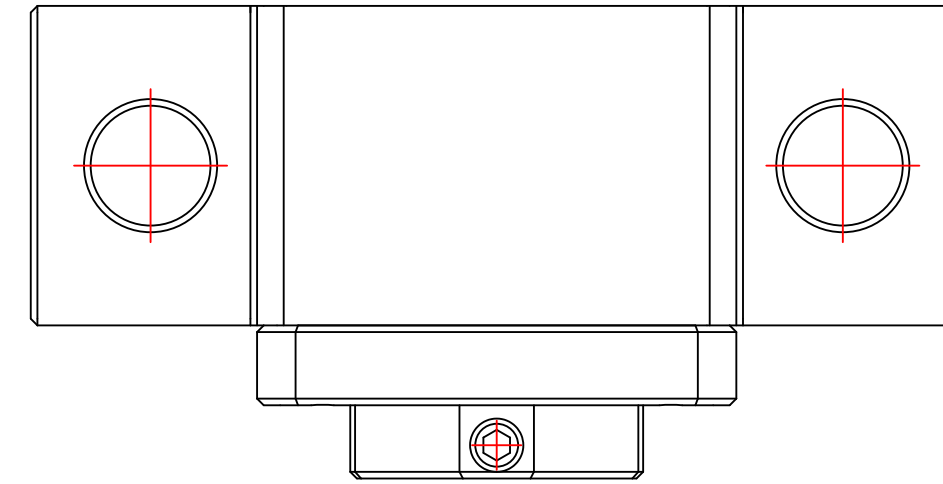

Section X-X

2- 9 thru

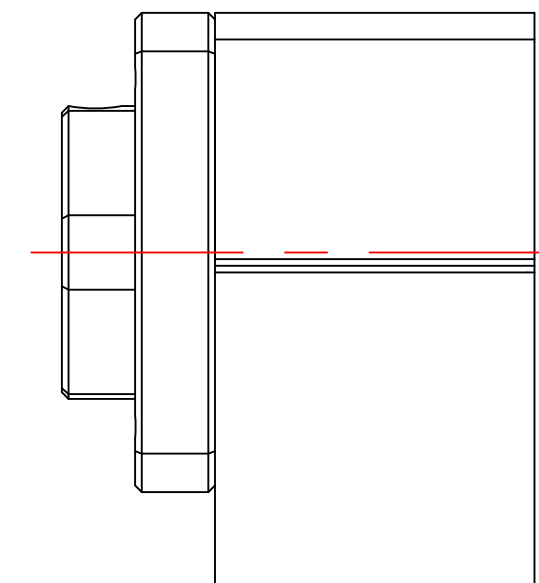
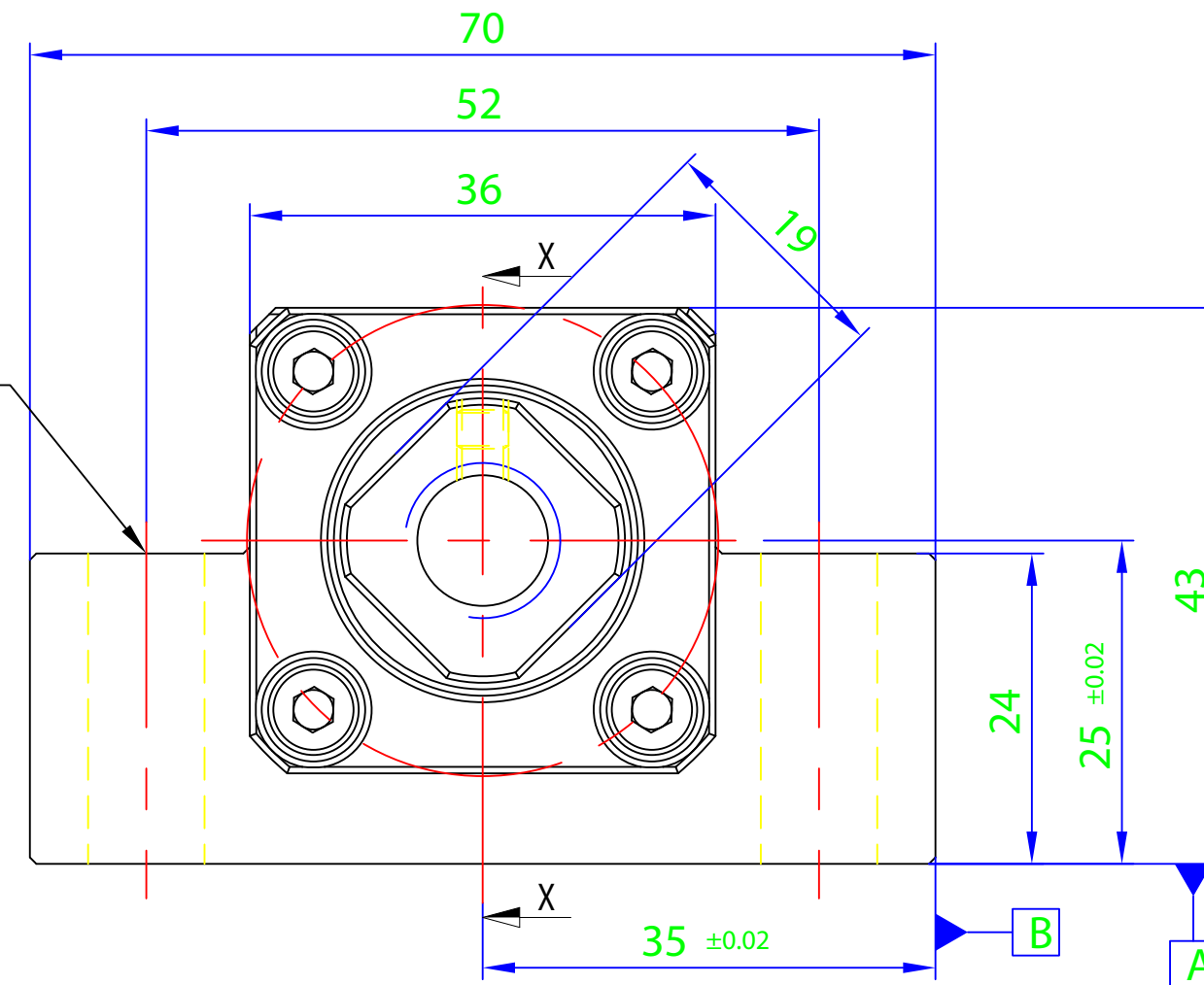

가공치수허용차		
범위	정밀급	보통급
0.5 ~ 6까지	±0.05	±0.1
6 ~ 30까지	±0.1	±0.2
30 ~ 120까지	±0.15	±0.3
120 ~ 315까지	±0.2	±0.5
315 ~ 1000까지	±0.3	±0.8
1000 ~ 2000까지	±0.5	±1.2
지시없는 모따기	R = 0.2~0.3	
빛 라운드	C = 0.2~0.3	

APPROVED BY
CHECKED BY
DRAWN BY



TITLE			
EK12 외관도			
SIZE	Dwg.NO. EK12-0000		
A	SCALE	1:1	DATE

MARK	REASON OF REVISIONS	REVISIONER	CHECKER	DATE	HEAT TREAT	APPROVED FINISH
REVISION						

NO	DESCRIPTION	SPECIFICATION	MAT'L	Q'TY	REMARK

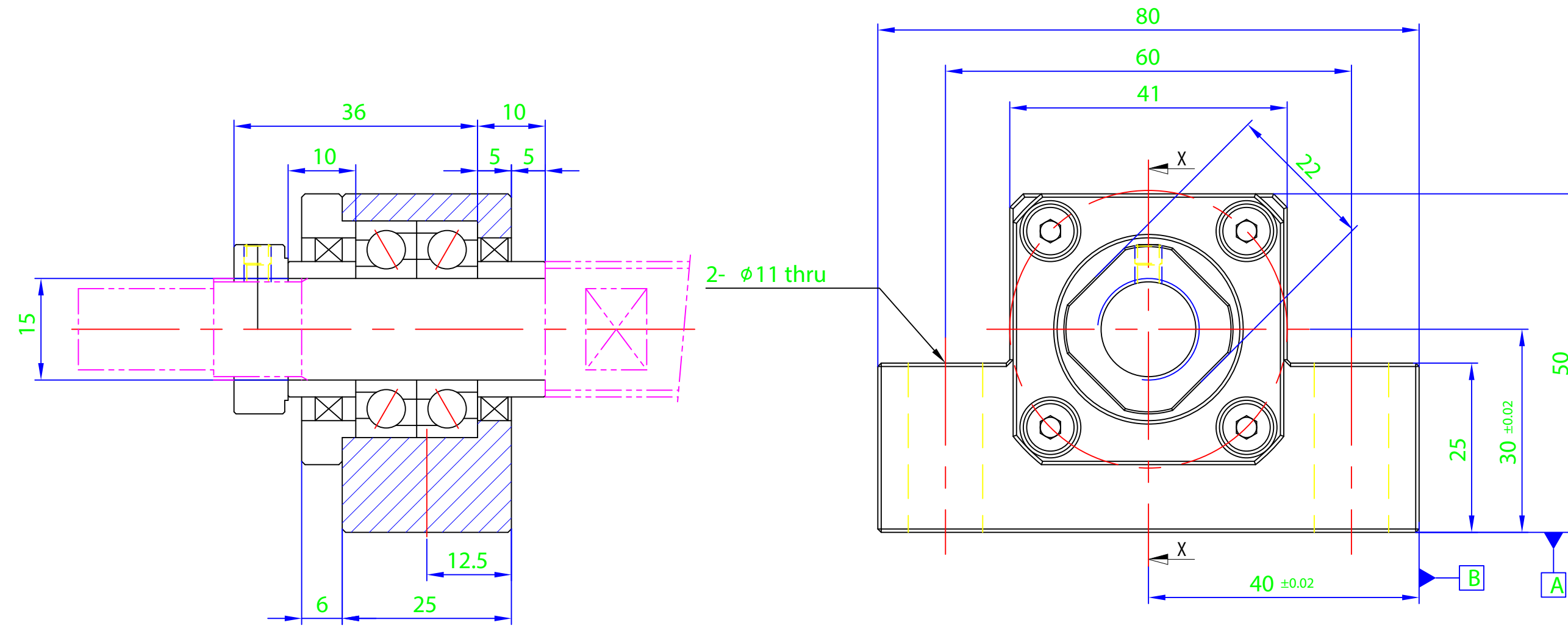
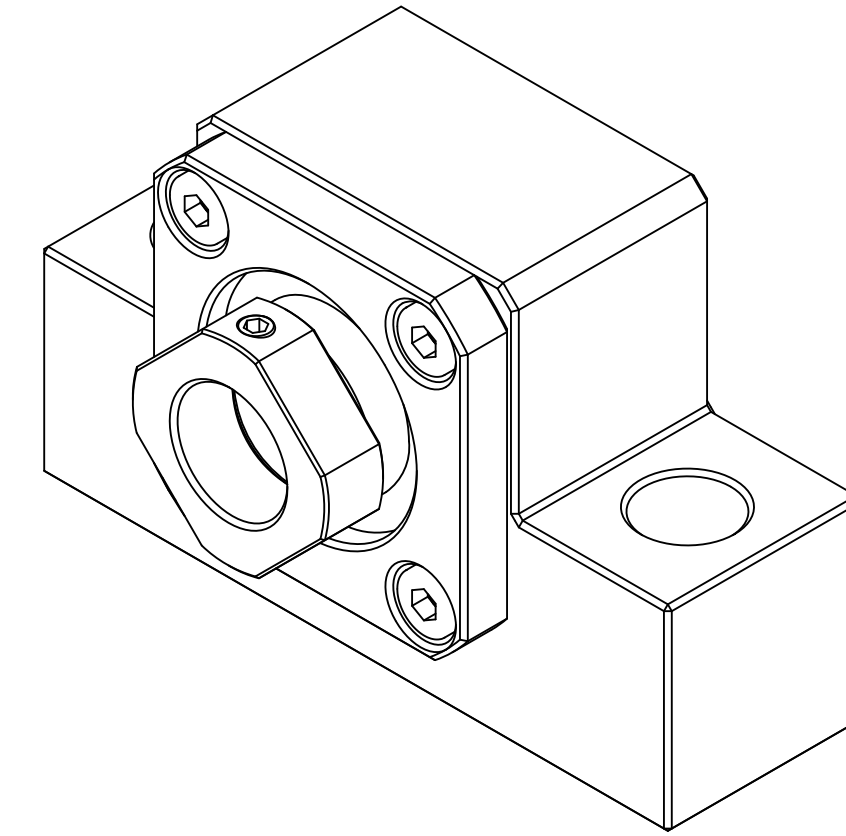
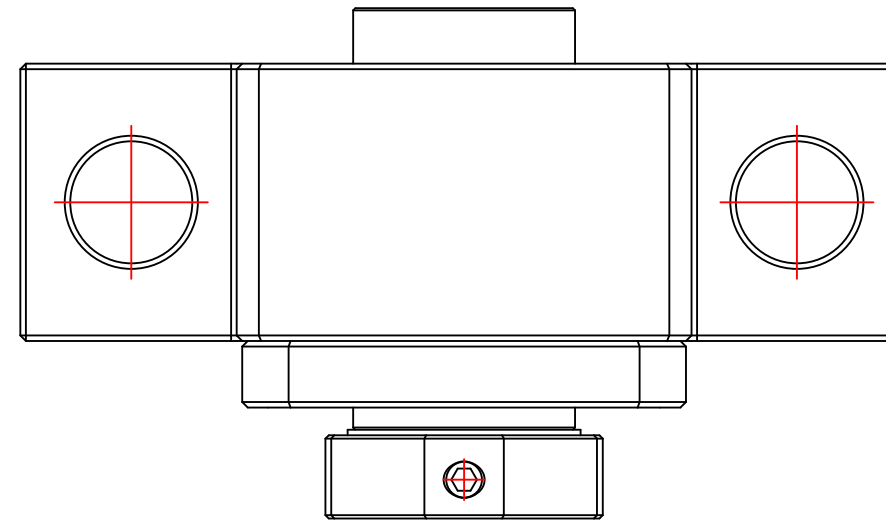

Section X-X

MARK	REASON OF REVISIONS	REVISIONER	CHECKER	DATE

REVISION

가공치수허용차	
범위	정밀급 보통급
0.5 ~ 6까지	±0.05 ±0.1
6 ~ 30까지	±0.1 ±0.2
30 ~ 120까지	±0.15 ±0.3
120 ~ 315까지	±0.2 ±0.5
315 ~ 1000까지	±0.3 ±0.8
1000 ~ 2000까지	±0.5 ±1.2
지시없는 모따기	R = 0.2~0.3
빛 라운드	C = 0.2~0.3

APPROVED BY	
CHECKED BY	
DRAWN BY	



TITLE		EK15 외관도	
SIZE	Dwg.NO. EK15-0000		
A	SCALE	1:1	DATE

NO	DESCRIPTION	SPECIFICATION	MAT'L	Q'TY	REMARK

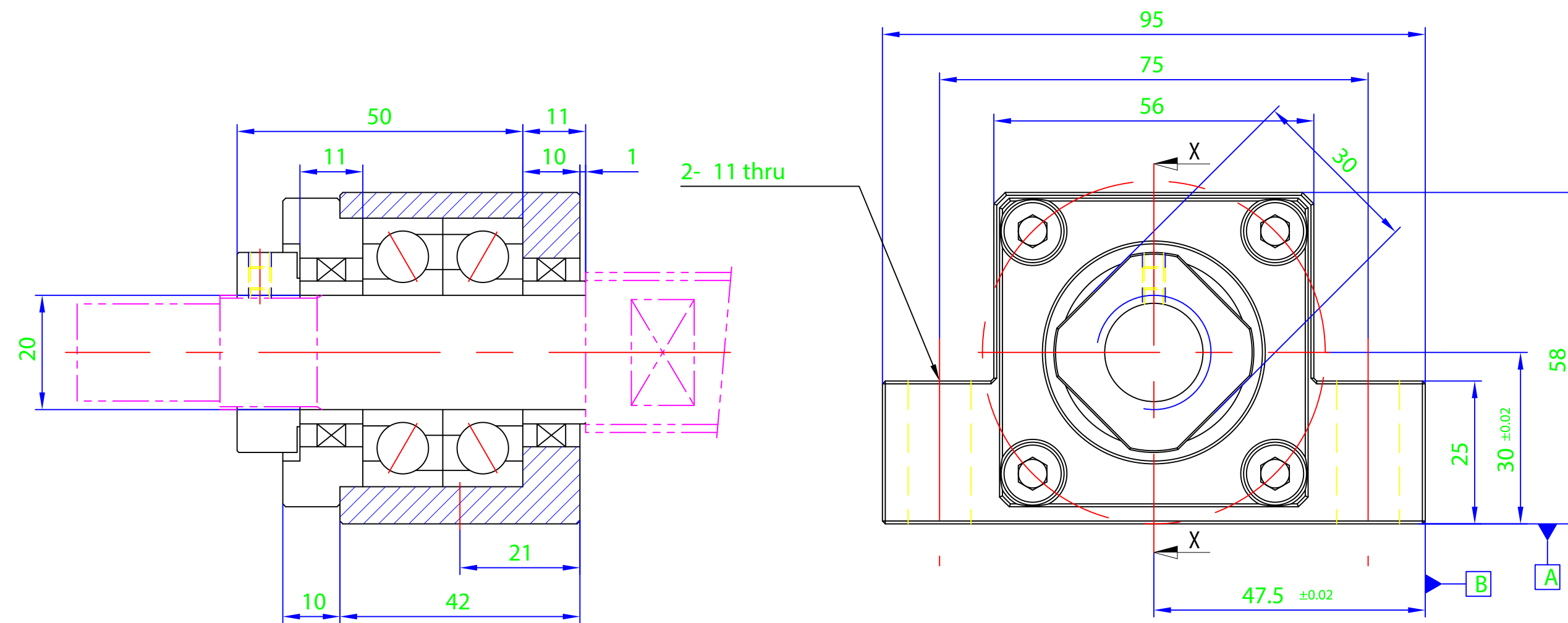
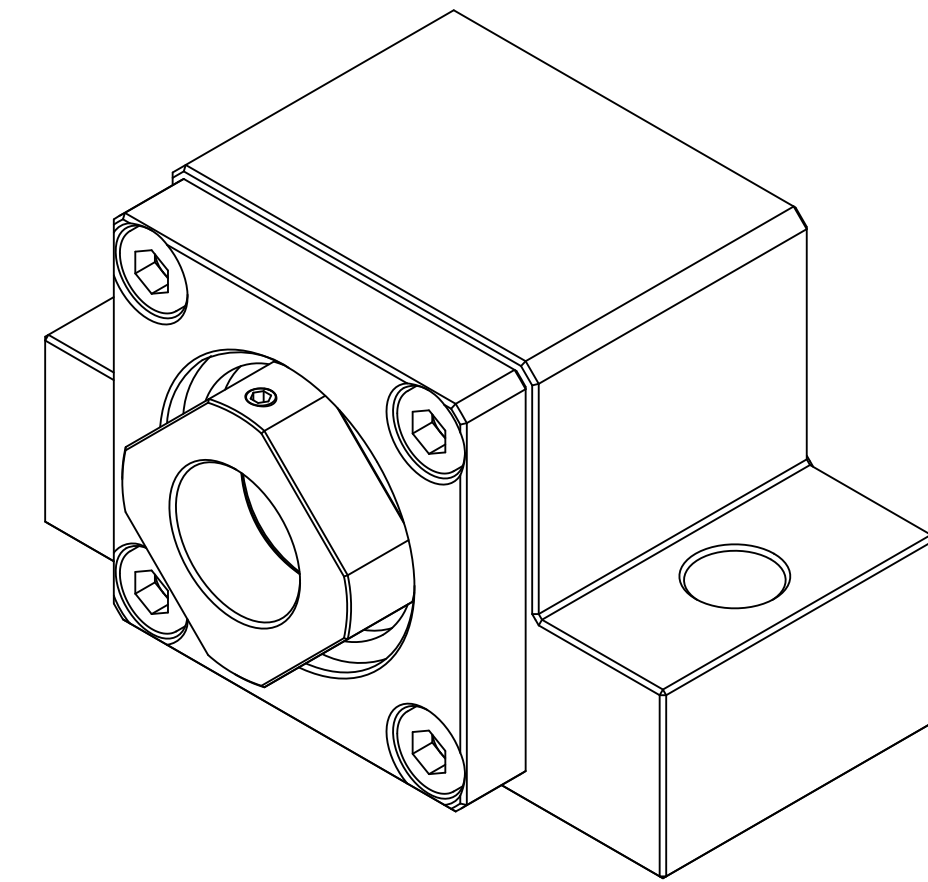
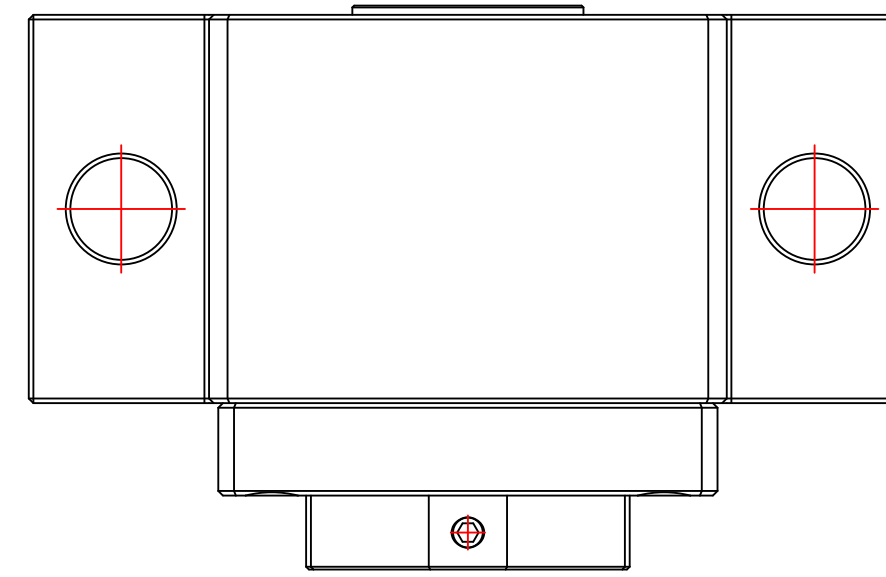

Section X-X

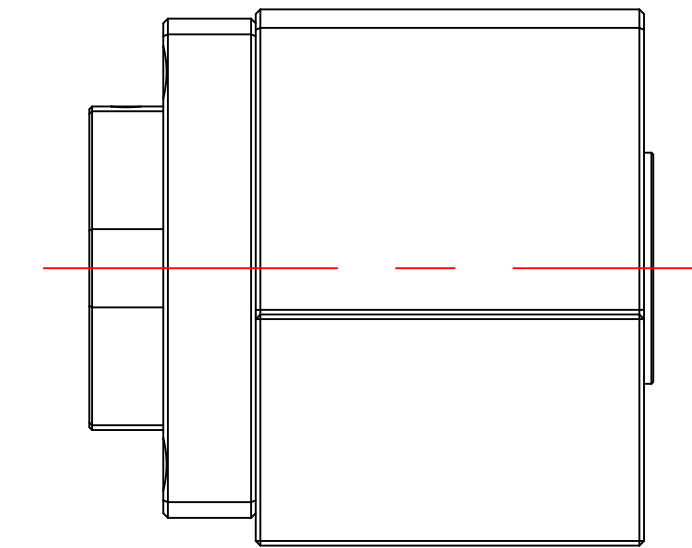

MARK	REASON OF REVISIONS	REVISIONER	CHECKER	DATE

REVISION

가공치수허용차		
범위	정밀급	보통급
0.5 ~ 6까지	±0.05	±0.1
6 ~ 30까지	±0.1	±0.2
30 ~ 120까지	±0.15	±0.3
120 ~ 315까지	±0.2	±0.5
315 ~ 1000까지	±0.3	±0.8
1000 ~ 2000까지	±0.5	±1.2
지시없는 모따기	R = 0.2~0.3	
빛 라운드	C = 0.2~0.3	

APPROVED BY	
CHECKED BY	
DRAWN BY	



TITLE			
EK20 외관도			
SIZE	Dwg.NO. EK20-0000		
A	SCALE	1:1	DATE

NO	DESCRIPTION	SPECIFICATION	MAT'L	Q'TY	REMARK

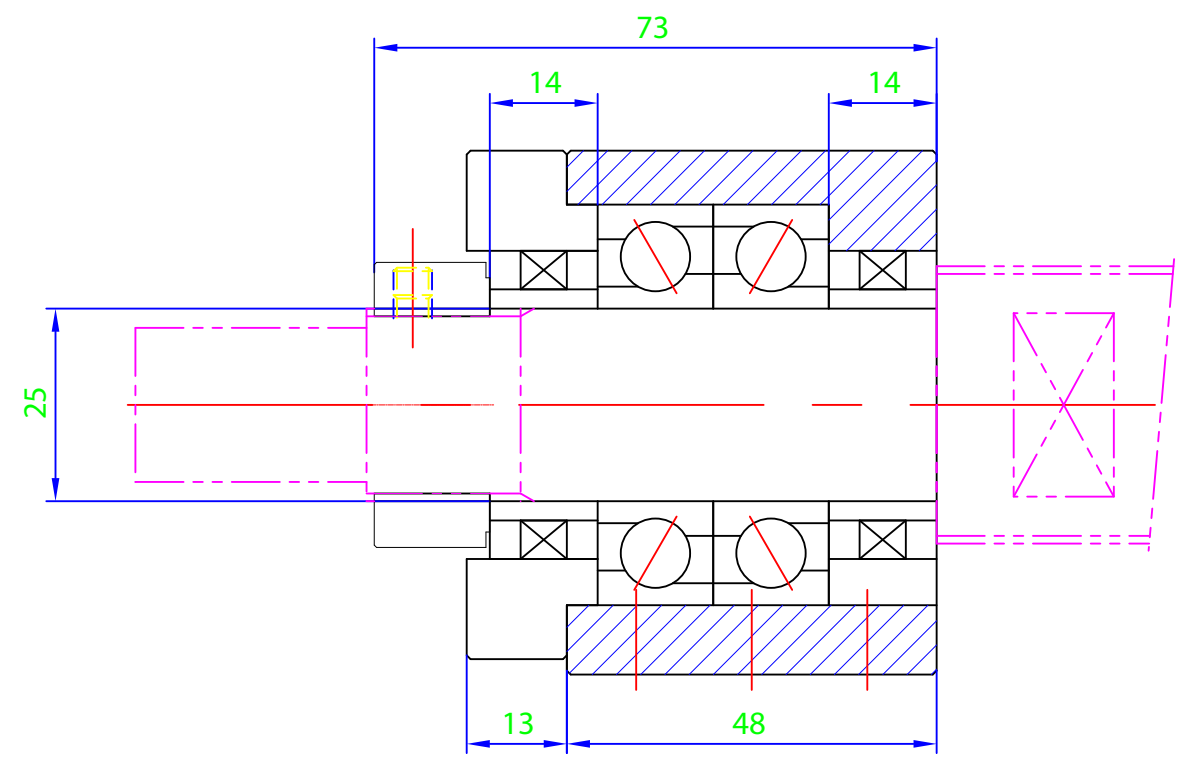
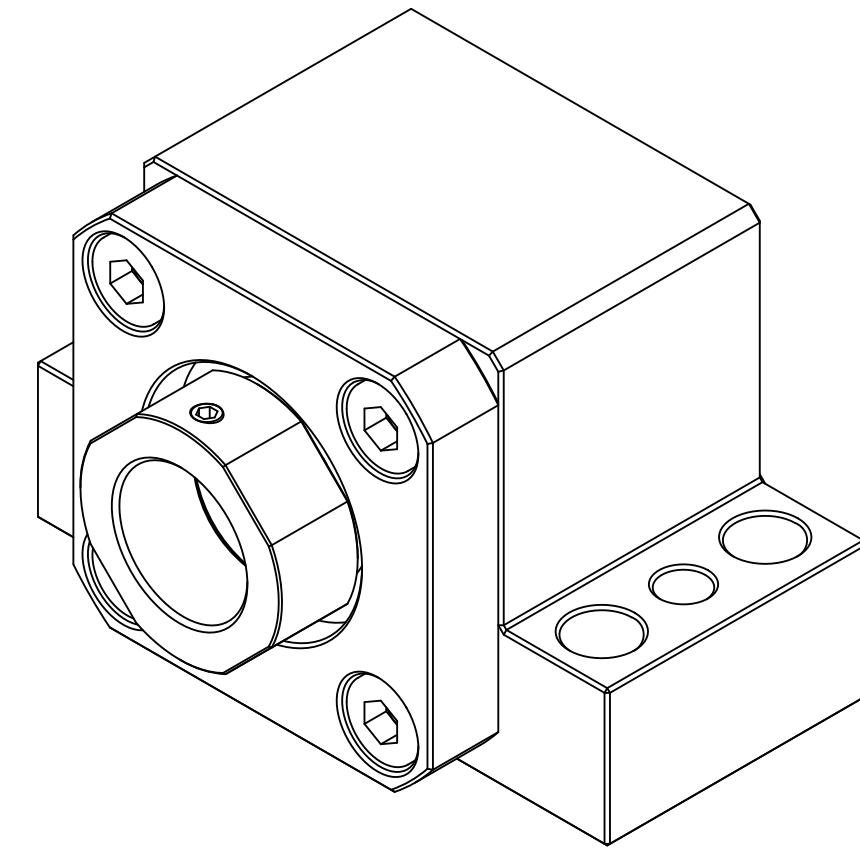
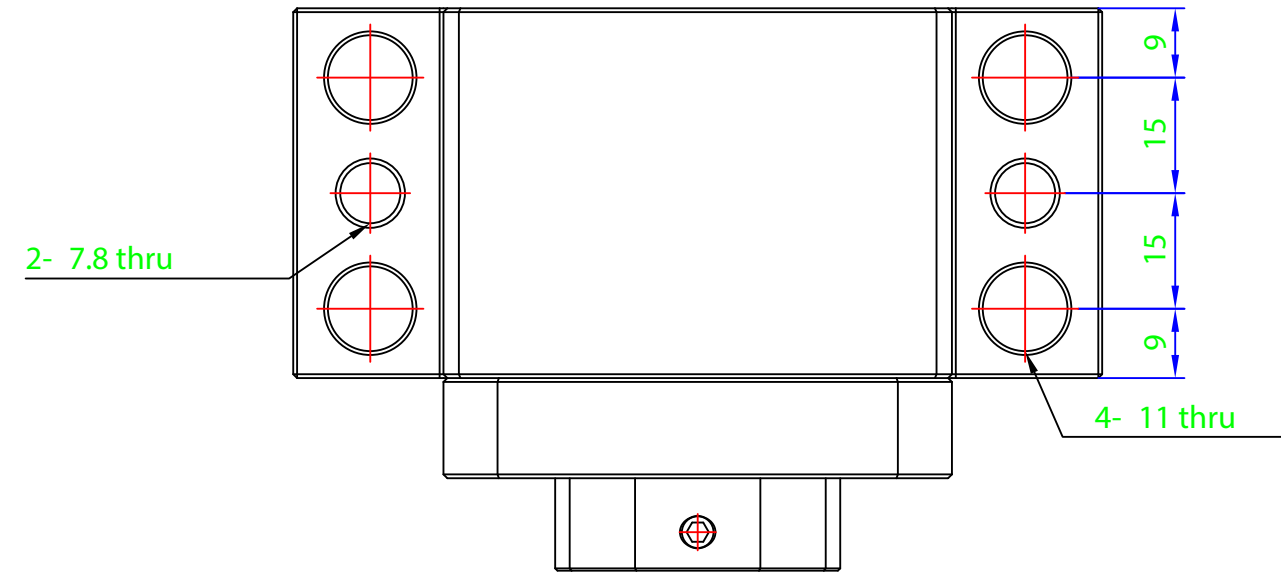

Section X-X

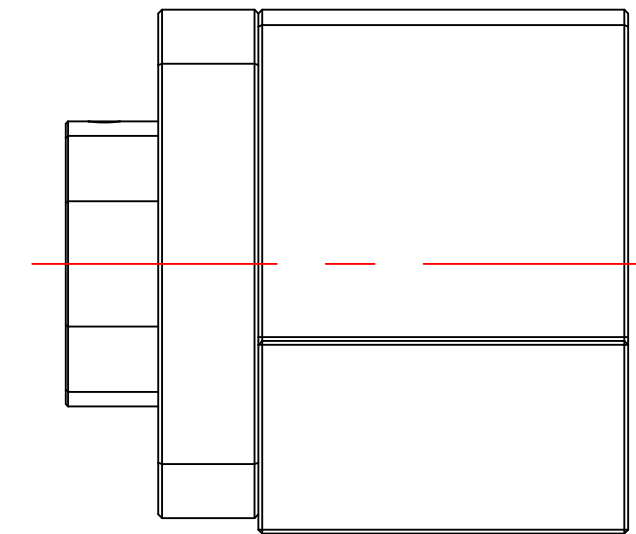
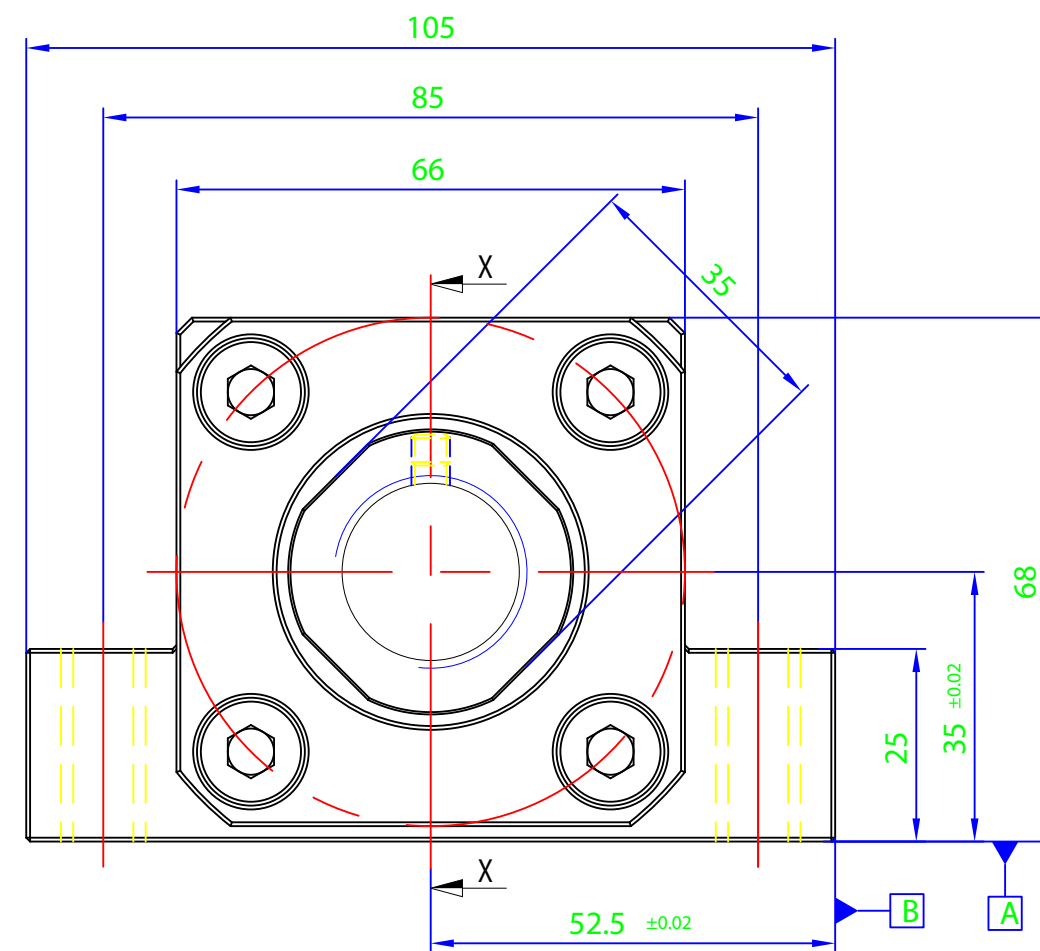

MARK	REASON OF REVISIONS	REVISIONER	CHECKER	DATE

REVISION

가공치수허용차		
범위	정밀급	보통급
0.5 ~ 6까지	±0.05	±0.1
6 ~ 30까지	±0.1	±0.2
30 ~ 120까지	±0.15	±0.3
120 ~ 315까지	±0.2	±0.5
315 ~ 1000까지	±0.3	±0.8
1000 ~ 2000까지	±0.5	±1.2
지시없는 모따기	R =	0.2~0.3
빛 라운드	C =	0.2~0.3

APPROVED BY
CHECKED BY
DRAWN BY

TITLE			
EK25 외관도			
SIZE	Dwg.NO. EK25-0000		
A	SCALE	1:1	DATE