

RIGID SPINDLE

ALSO IN STAINLESS STEEL (See table)

Code	Description	Stainless steel Code	Description	A	B	D
AU099	10099	AU509	50099	20	3	M4
AU100	10100	AU510	50100	35	3,5	M5
AU101	10101	AU511	50101	45	4	M6
AU102	10102	AU512	50102	55	5	M8
AU103	10103			70	6	M10
AU104	10104			80	8	M12
AU105	10105			120	8	M12

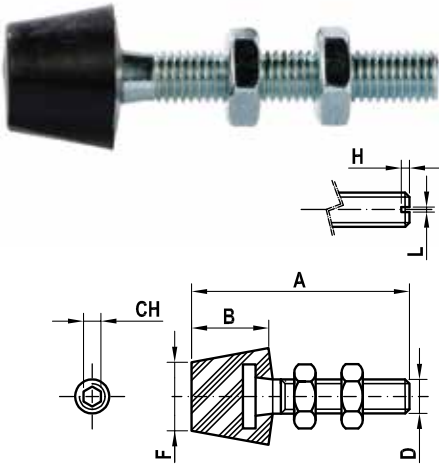

NEOPRENE SPINDLE

ALSO IN STAINLESS STEEL (See table)

Code	Description	Stainless steel Code	Description	A	B	D	F	CH	L	H
AU139	10139	AU539	50139	25	5	M4	6			
AU140	10140	AU540	50140	45	11	M5	10	2,5		
AU141	10141	AU541	50141	55	12	M6	12,5	3		
AU142	10142	AU542	50142	70	16	M8	16	4		
AU143	10143			77	20	M10	20	5		
AU144	10144			100	25	M12	24		2	2,8
AU145	10145			130	25	M12	24		2	2,8

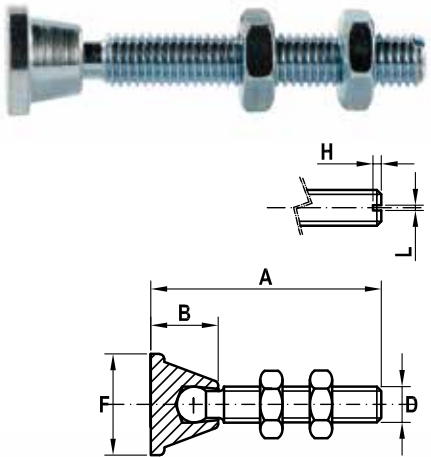

ARTICULATED SPINDLE

ALSO IN STAINLESS STEEL (See table)

Code	Description	Stainless steel Code	Description	A	B	D	F	L	H
AU120	10120	AU520	50120	36	9,5	M5	14	0,8	1,25
AU121	10121	AU521	50121	46	10	M6	16	1	1,6
AU122	10122	AU522	50122	65	12	M8	18	1,2	2
AU123	10123			75	14	M10	20	1,6	2,4
AU124	10124			85	16	M12	24	2	2,8
AU125	10125			125	16	M12	24	2	2,8

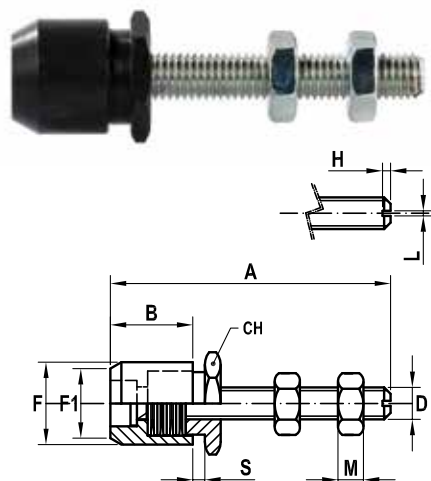

SPRING SPINDLE

Code	Description	A	B	D	F	F1	M	CH	L	H
AU128	10128	45	13	M5	13	11	4	14	0,8	1,25
AU129	10129	50	15	M6	16	13	4	16	1	1,6
AU130	10130	70	17	M8	18	15	5	18	1,2	3
AU131	10131	85	20	M10	24	18	6	24	1,6	2,4
AU132	10132	106	24	M12	28	21	7	27	2	2,8

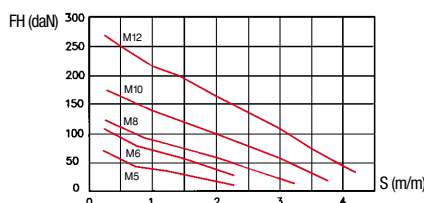

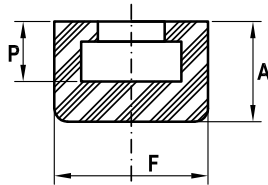

NEOPRENE CAP

Code	Description	A	F	P	For spindle
AU109	1099	6,5	11	4	10099-M4
AU110	1100	8	12	5,5	10100-M5
AU111	1101	10	15	6	10101-M6
AU112	1102	13	19	7,5	10102-M8
AU113	1103	16	24	9	10103-M10
AU114	1104	19	26	10,5	10104-10105-M12

THREADED NEOPRENE CAP

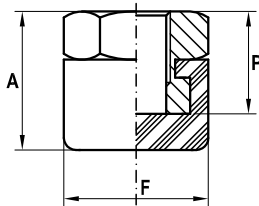

Code	Description	A	F	P	For spindle
AU200	1200	11	12,5	8,5	M5
AU201	1201	14	15	10	M6
AU202	1202	18	19	12,5	M8
AU203	1203	23	24	16	M10
AU204	1204	26,6	26	18	M12

PROXIMITY SWITCHES

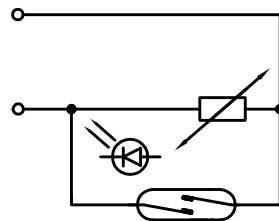

AU450 for models

400/APM/EPM - 2100/SPM

AU460 for models

200/APM/EPM - 300/APM/EPM

200/APVM/EPVM - 200/APVMS/EPVMS

300/APVM/EPVM - 300/APVMS/EPVMS

360/SPM - 1100/SPM

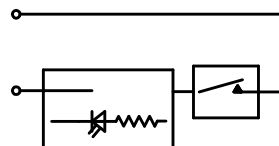

AU470 for models

1000/EPM/EPVM

2000/EPM/EPVM

AU570 for models

1000/EPM/EPVM

2000/EPM/EPVM

LPV1/2/3 - 75-130-230-330-430/AP/EP/APV/EPV/

APVS/EPVS - 70-360-1100-2100/SP4



ERGONOMIC HANDLE

Code	Description	Used for series
AU150	10150	75/A-B-E-F-M-MF-N-O-P-ML-NL-OL-PL**50/ASD-ASS**70/AS-ASD-ASS**80/AS**160/T6 "Also for the Stainless steel series"
AU151	10151	120/AS**130/M-N-O-P-MF-A-B-E-F-ML-NL-OL-PLS-PLS**LLA-LLB-LLE-LLF/01 "Also for the Stainless steel series"
AU152	10152	200/AVF-EVF**230/A-B-E-F-AL-BL-EL-ELS-FL-FLS-M-MF-N-O-P**165/AS**320/T6**200/ APV3S-APVMS-EPV3S-EPVMS** "Also for the Stainless steel series"
AU153	10153	200/AV-EV**300/AVF-EVF**330/A-B-E-F**550/ASD-ASS**300/AS**550/AS**200/ T-TF**33/T-TF-TL-TFL**700/T6**300/APV3S-APVMS-EPV3S-EPVMS "Also for the Stainless steel series"
AU154	10154	300/AV-EV**430/A-B-E-F**LLA-LLB-LLE-LLF/02**1100/AS**340/AS**300/T-TF**43/ T-TF-TL-TFL**1400/T5**355/M-MF-N-O-P "Also for the Stainless steel series"
AU155	10155	530/A-B-E-F**2100/AS**3100/AS**400-T-TF**455/M-MF-N-O-P
AU156	10156	LLE-LLF/03**1000/F**2000/F
AU157	10157	LLE-LLF/04**3000/F
AU158	10158	160/AS-ASD-ASS**230/OLS-PLS
AU159	10159	230/ML-NL-OL-PL "Also for the Stainless steel series"
AU160	10160	355/ML-NL-OL-PL
AU161	10161	455/ML-NL-OL-PL

FLANGED WASHER

ALSO IN STAINLESS STEEL (See table)



Code	Description	Stainless steel Code	Description	Used for series	For spindle
AU205	20105	AU505	50105	25/M-MX	M4
AU206	20106	AU506	50106	70/AP3-75/M-N-MF-A-B-ML-NL "Also for the Stainless steel series"	M5
AU207	20107	AU507	50107	AT6-AP6 (NO INOX) 130/M-N-MF-A-B-ML-NL-AL-BL "Also for the Stainless steel series"	M6
AU208	20108	AU508	50108	AT8-AP8 (NO INOX) 200/AV-APM-AP3-APV3-APVM-APV3S- APVMS-AVF-230/M-N-MF-A-B-ML-NL-AL-BL "Also for the Stainless steel series"	M8
AU209	20109			300/A-B-AV-APV3S-APVMS-APM-APV3-APVM-AP3-AVF-330/A- B-355/M-N-MF-ML-NL	M10
AU210	20110			400/AP3-APM-430/A-B-455/M-N-ML-NL-530/A	M12
AU211	20111			LLA-B/01	M6
AU212	20112			LLA-B/02	M10

BOLT RETAINER BAND

ALSO IN STAINLESS STEEL (See table)



Code	Description	Stainless steel Code	Description	Used for series	For spindle
AU180	10180	AU580	50180	70/EP3-75/O-P-E-F-OL-PL "Also for the Stainless steel series"	M5
AU181	10181	AU581	50181	125/EP3	M6
AU182	10182	AU582	50182	200/EV-EPM-EP3-EPV3-EPVM-EPV3S-EPVMS-EVF-230/ O-P-E-F-OL-PL-EL-FL "Also for the Stainless steel series"	M8
AU183	10183			300/EV-EPV3S-EPVMS-EPM-EPV3-EPVM-EP3-EVF	M10
AU184	10184			330/E-F-355/O-P-OL-PL	M12
AU185	10185			400/EP3-EPM	M12
AU186	10186			430/E-F-455/O-P-OL-PL	M12
AU189	10189	AU589	50189	130/O-P-E-F-OL-PL-EL-FL "Also for the Stainless steel series"	M6
AU190	10190			530/E-F	M12



EXTENSION

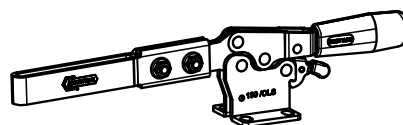
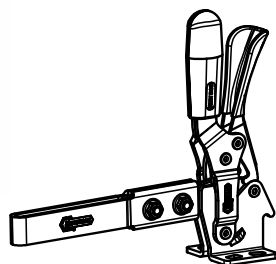
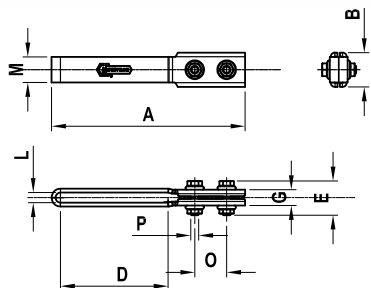

Code	Description	A	B	D	E	G	L	M	O	P	Q	gr.	Can be applied to the tools
AU340	AP6	121	21,5	67,5	21,5	10	6,3	16	20	M5		95	130/OLS/PLS/ELS/FLS
AU342	AP8	142	24,5	71,5	26,5	12	8,2	18	26	M6		165	230/OLS/PLS/ELS/FLS

CROSS BAR

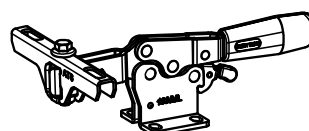
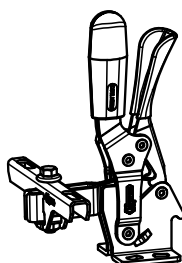
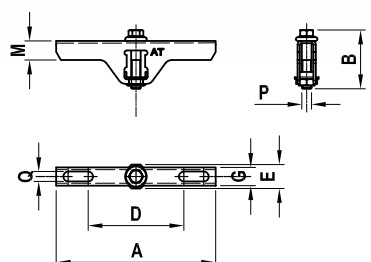

Code	Description	A	B	D	E	G	L	M	O	P	Q	gr.	Can be applied to the tools
AU320	AT6	100	37	60-85	15	11,5		12		M6	6,2	50	130 VER.-130 HORIZ.-125/AP3
AU322	AT8	120	43	70-100	18	14		15,5		M8	8,2	96	230 VER.- 230 HORIZ.- 200/AP3

ARTICULATED CROSS BAR

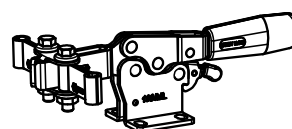
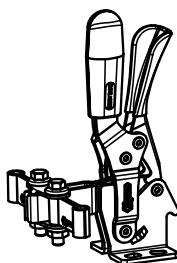
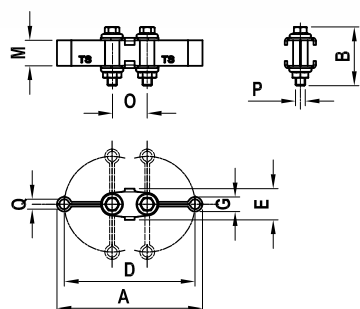

Code	Description	A	B	D	E	G	L	M	O	P	Q	gr.	Can be applied to the tools
AU330	TS6	91	37	82	19,5	9,2		16	22	M6	6,2	70	130 VER.- 130 HORIZ.- 125AP3
AU332	TS8	112	43	100	26	12		18	27	M8	8	120	230 VER.- 230 HORIZ.- 200AP3