





HORIZONTAL SERIES

The control and clamping levers move in opposite directions. When clamping is obtained, the control lever is in the horizontal position. Available with clamping forces between 40 and 620 daN.

PERFORMANCE

Parts made of case-hardening sheet steel. Hardened and tempered supporting pivots. Supporting bushes (for sizes from 350 daN and over) undergo case-hardening and grinding. Finish: Galvanized. The shape of the tool ensures a safe distance between the clamping and control lever that prevents the operator's fingers from getting stuck during the opening of the tool.

The clamping lever is guided in the locked position for additional stability any sideways movement.

In order to prevent accidental openings, caused by vibrations, some tools of this series are provided with a device called "safety device", suitable for maintaining the clamp in a closed position.

HORIZONTAL SERIES WITH FOLDED BASE

Some sizes of this series are also produced in stainless steel and are shown below in red.

Material:

Galvanized steel or **AISI 304 stainless steel**

Riveted pivots:

Galvanized steel or **AISI 304 stainless steel**

Supporting bushes:

Hardened and ground steel (for sizes ≥ 355).

Handles:

Red polyurethane resistant to oils, grease and other chemical agents.

Performance:

Form M and **form MX** with open clamping lever and two flanged washers.

Form O and **form OX** with full clamping lever and bolt retainers to be welded in the desired position and angle.

Spindles: To be ordered separately (see Accessories on page 87).

Features and applications:

The main feature of this series is the low profile of the tool; these tools are designed to prevent the operator's fingers from being crushed by the levers when opening. During the closing, the clamping lever is guided laterally to ensure greater stability against possible transverse stresses. A special grease is placed between two contacting surfaces during assembly.

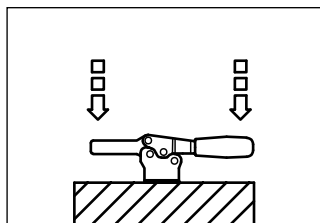

FORM M

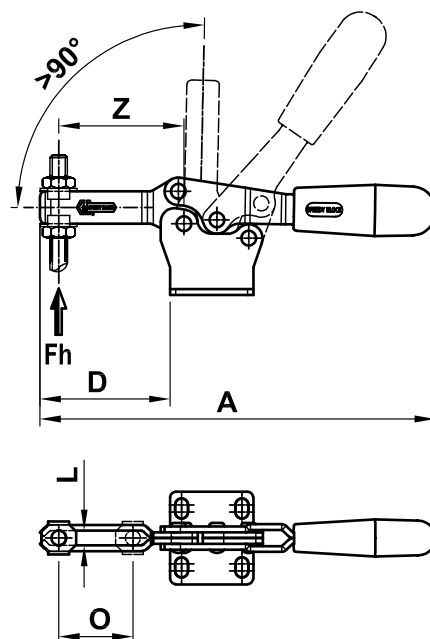

FORM O

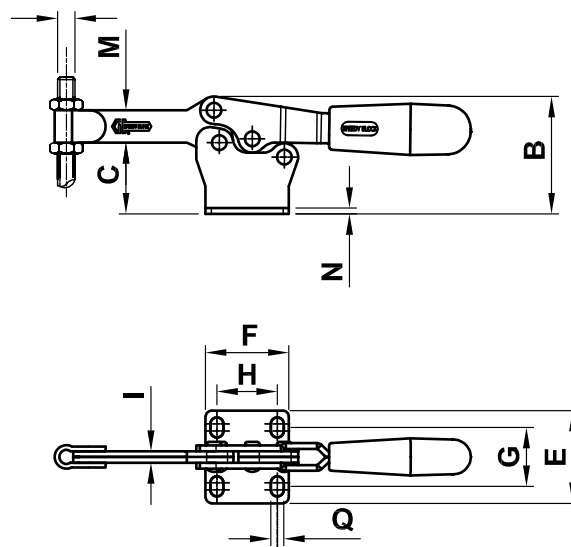

Code	Description	Stainless steel Code	Description	A	B	C	D	E	F	G	H	I	L	M	N	O	P	Q	Z	Fh (daN)	gr.
AD025	25/M	DS025	25/MX	68	23	12	19	24,5	24	16	15		4,2	7	1,2	10	M4	4,3	21	40	25
AD075	75/M	DS075	75/MX	118	37	20	39	26	28	16÷19	13,5		5,3	11	2	20	M5	4,5	36	90	88
AD085	75/O	DS085	75/OX	118,5	37	20	39,5	26	28	16÷19	13,5	4		11	2		M5	4,5		90	88
AD135	130/M	DS135	130/MX	171,5	51	30,5	56,5	40	36	22,4÷28,4	26		6,3	16	2,5	32	M6	5,6	55	100	200
AD145	130/O	DS145	130/OX	172	51	30,5	57	40	36	22,4÷28,4	26	5		16	2,5		M6	5,6		100	200
AD270	230/M	DS270	230/MX	196	61,5	36,5	65	44	44	26÷31,5	26		8,5	18	3	37	M8	6,6	62	170	330
AD280	230/O	DS280	230/OX	196,5	61,5	36,5	66	44	44	26÷31,5	26	6		18	3		M8	6,6		170	340
AD370	355/M			270	83	50	100	58	60	38,8÷43	41		10,5	22	3,5	58	M10	8,6	98	180	700
AD380	355/O			270	83	50	101	58	60	38,8÷43	41	7		22	3,5		M10	8,6		180	720
AD470	455/M			305	99	60	113	65	70	40÷43	41,5		12,5	26	4	65	M12	8,7	113	320	1200
AD480	455/O			306,5	99	60	115,5	65	70	40÷43	41,5	10		26	4		M12	8,7		320	1230

FORM N

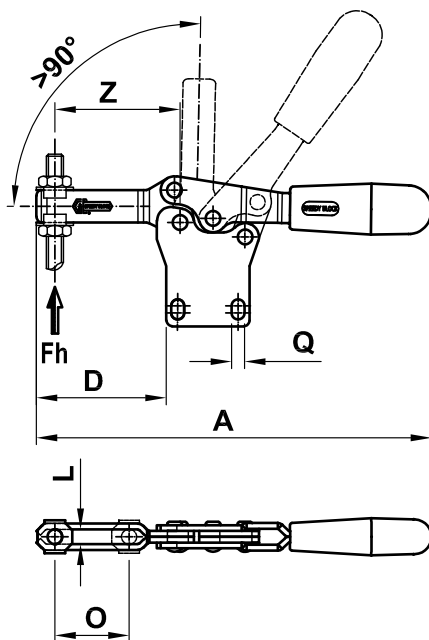

HORIZONTAL SERIES WITH STRAIGHT BASE.

Some sizes of this series are also produced in stainless steel and are shown below in red.

Material:

Galvanized steel or **AISI 304 stainless steel**

Riveted pivots:

Galvanized steel or **AISI 304 stainless steel**

Supporting bushes:

Hardened and ground steel (for sizes ≥ 355).

Handles:

Red polyurethane resistant to oils, grease and other chemical agents.

Performance:

Form N and **form NX** with open clamping lever and two flanged washers.

Form P and **form PX** with full clamping lever and bolt retainers to be welded in the desired position and angle.

Spindles:

To be ordered separately (see Accessories on page 87).

Features and applications:

The main feature of this series is the low profile of the tool; these tools are designed to prevent the operator's fingers from being crushed by the levers when opening. During the closing, the clamping lever is guided laterally to ensure greater stability against possible transverse stresses. A special grease is placed between two contacting surfaces during assembly.

FORM P

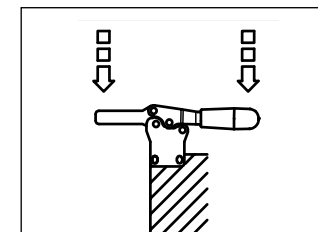
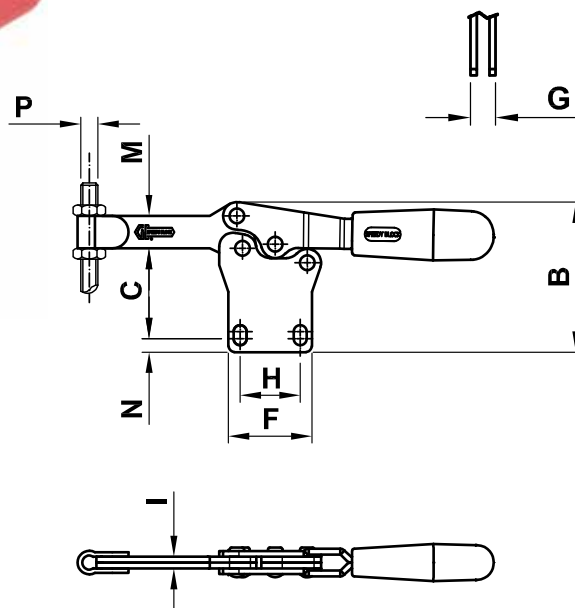

Code	Description	Stainless steel Code	Description	A	B	C	D	F	G	H	I	L	M	N	O	P	Q	Z	Fh (daN)	gr.
AD080	75/N	DS080	75/NX	118	45,5	24÷25,5	39	28	8	13,5		5,3	11	5÷3,5	20	M5	4,5	36	90	88
AD090	75/P	DS090	75/PX	118,5	45,5	24÷25,5	39,5	28	8	13,5	4		11	5÷3,5		M5	4,5		90	88
AD140	130/N	DS140	130/NX	171,5	64,5	35÷38	56,5	36	10	26		6,3	16	8,8÷5,8	32	M6	5,6	55	100	200
AD150	130/P	DS150	130/PX	172	64,5	35÷38	57	36	10	26	5		16	8,8÷5,8		M6	5,6		100	200
AD275	230/N	DS275	230/NX	196	75,5	42÷44,5	65	44	12	26		8,5	18	9÷6,5	37	M8	6,6	62	170	330
AD285	230/P	DS285	230/PX	196,5	75,5	42÷44,5	67	44	12	26	6		18	9÷6,5		M8	6,6		170	340
AD375	355/N			270	103	60÷62	100	60	14	41		10,5	22	9,6÷7,5	58	M10	8,6	98	180	700
AD385	355/P			270	103	60÷62	101	60	14	41	7		22	9,6÷7,5		M10	8,6		180	720
AD475	455/N			305	120	68÷69,5	113	70	18	41,5		12,5	26	12,5÷11	65	M12	8,7	113	320	1200
AD485	455/P			306,5	120	68÷69,5	115,5	70	18	41,5	10		26	12,5÷11		M12	8,7		320	1230

HORIZONTAL SERIES WITH FOLDED BASE AND WITH SAFETY LEVER

Some sizes of this series are also produced in stainless steel and are shown below in red.

Material:

Galvanized steel or **AISI 304 stainless steel**

Riveted pivots:

Galvanized steel or **AISI 304 stainless steel**

Supporting bushes:

Hardened and ground steel (for sizes ≥ 355).

Handles:

Red polyurethane resistant to oils, grease and other chemical agents.

Performance:

Form ML and **form MLX** with open clamping lever and two flanged washers.

Form OL and **form OLX** with full clamping lever and bolt retainers to be welded in the desired position and angle.

Spindles:

To be ordered separately (see Accessories on page 87).

Features and applications: The main feature of this series is the special anti-release lever with the purpose of avoiding any accidental openings caused by vibrations; these tools are designed to prevent the operator's fingers from being crushed by the levers when opening. During the closing, the clamping lever is guided laterally to ensure greater stability against possible transverse stresses. A special grease is placed between two contacting surfaces during assembly.

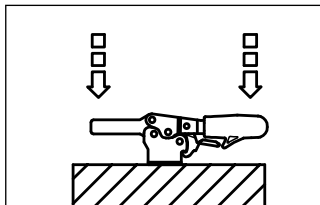

FORM ML

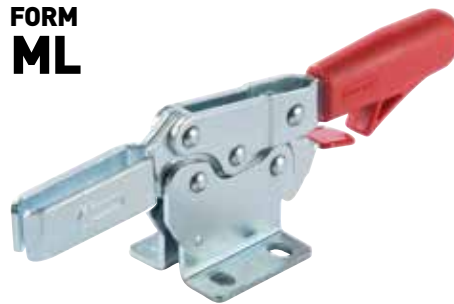

PATENTED

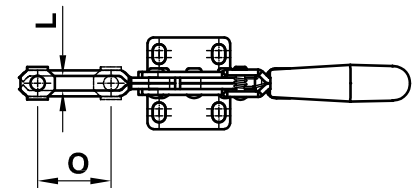
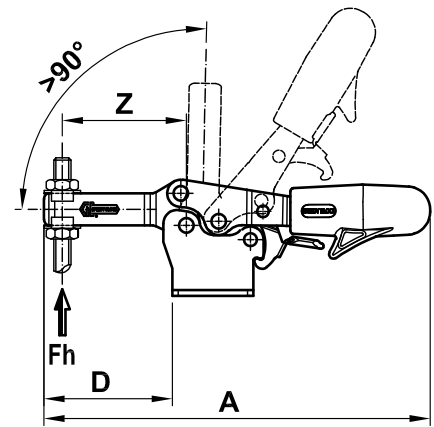

FORM OL



PATENTED

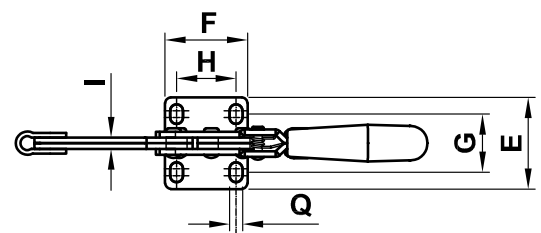
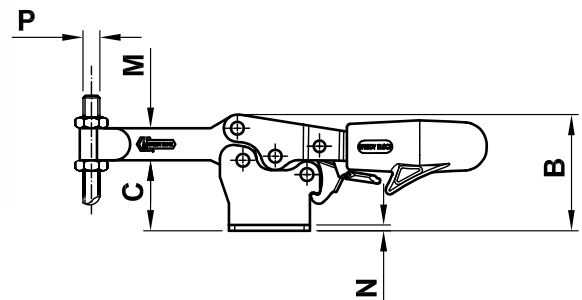

Code	Description	Stainless steel Code	Description	A	B	C	D	E	F	G	H	I	L	M	N	O	P	Q	Z	Fh (daN)	gr.
AD092	75/ML	DS100	75/MLX	118	37	20	39	26	28	16÷19	13,5		5,3	11	2	20	M5	4,5	36	90	90
AD096	75/OL	DS104	75/OLX	118,5	37	20	39,5	26	28	16÷19	13,5	4		11	2		M5	4,5		90	90
AD152	130/ML	DS152	130/MLX	171,5	51	30,5	56,5	40	36	22,4÷28,4	26		6,3	16	2,5	32	M6	5,6	55	100	200
AD156	130/OL	DS156	130/OLX	172	51	30,5	57	40	36	22,4÷28,4	26	5		16	2,5		M6	5,6		100	200
AD290	230/ML	DS287	230/MLX	196	61,5	36,5	65	44	44	26÷31,5	26		8,5	18	3	37	M8	6,6	62	170	320
AD294	230/OL	DS291	230/OLX	196,5	61,5	36,5	66	44	44	26÷31,5	26	6		18	3		M8	6,6		170	330
AD390	355/ML			270	83	50	100	58	60	38,8÷43	41		10,5	22	3,5	58	M10	8,6	98	180	750
AD394	355/OL			271	83	50	101	58	60	38,8÷43	41	7		22	3,5		M10	8,6		180	750
AD490	455/ML			305	99	60	113	65	70	40÷43	41,5		12,5	26	4	65	M12	8,7	113	320	1200
AD494	455/OL			306,5	99	60	115,5	65	70	40÷43	41,5	10		26	4		M12	8,7		320	1220

FORM NL



PATENTED

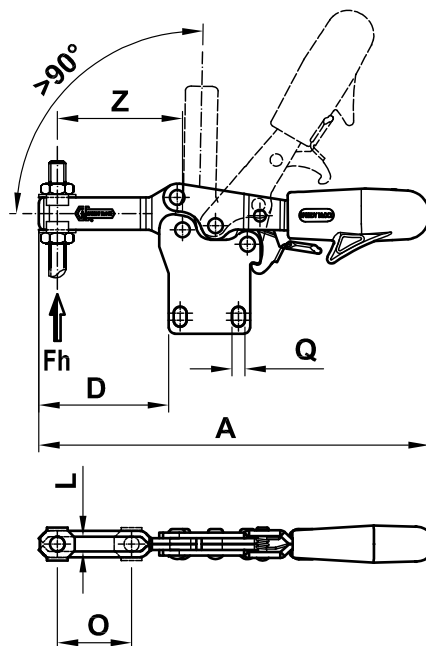

HORIZONTAL SERIES WITH STRAIGHT BASE AND WITH ANTI-RELEASE LEVER

Some sizes of this series are also produced in stainless steel and are shown below in red.

Material:

Galvanized steel or **AISI 304 stainless steel**

Riveted pivots:

Galvanized steel or **AISI 304 stainless steel**

Supporting bushes:

Hardened and ground steel (for sizes ≥ 355).

Handles:

Red polyurethane resistant to oils, grease and other chemical agents.

Performance:

Form NL and **form NLX** with open clamping lever and two flanged washers.

Form PL and **form PLX** with full clamping lever and bolt retainers to be welded in the desired position and angle.

Spindles:

To be ordered separately (see Accessories on page 87).

Features and applications:

The main feature of this series is the special anti-release lever with the purpose of avoiding any accidental openings caused by vibrations; these tools are designed to prevent the operator's fingers from being crushed by the levers when opening. During the closing, the clamping lever is guided laterally to ensure greater stability against possible transverse stresses. A special grease is placed between two contacting surfaces during assembly.

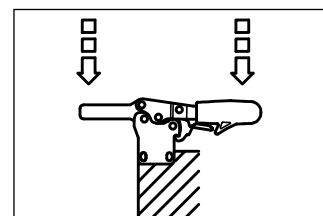

FORM PL

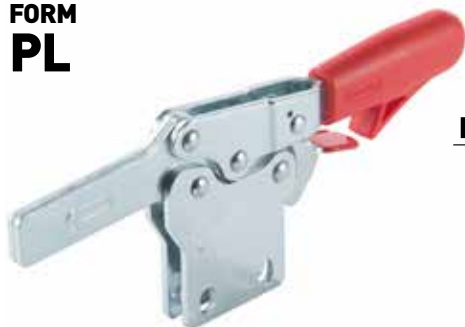

PATENTED

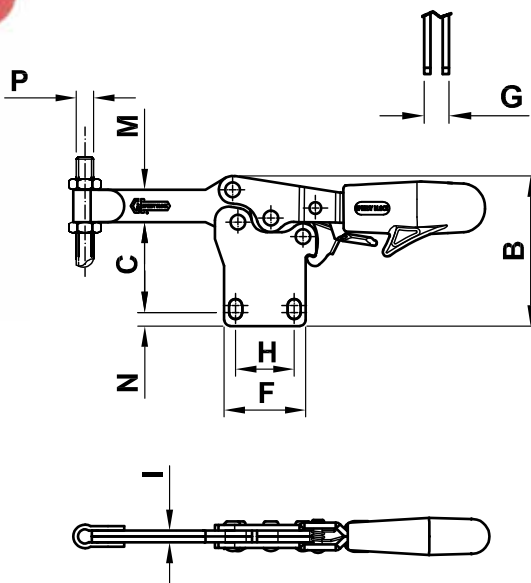

Codice	Descrizione	Stainless steel Code	Description	A	B	C	D	F	G	H	I	L	M	N	O	P	Q	Z	Fh (daN)	gr.
AD094	75/NL	DS102	75/NLX	118	45,5	24÷25,5	39	28	8	13,5		5,3	11	5÷3,5	20	M5	4,5	36	90	90
AD098	75/PL	DS106	75/PLX	118,5	45,5	24÷25,5	39,5	28	8	13,5	4		11	5÷3,5		M5	4,5		90	90
AD154	130/NL	DS154	130/NLX	171,5	64,5	35÷38	56,5	36	10	26		6,3	16	8,8÷5,8	32	M6	5,6	55	100	200
AD158	130/PL	DS158	130/PLX	172	64,5	35÷38	57	36	10	26	5		16	8,8÷5,8		M6	5,6		100	200
AD292	230/NL	DS289	230/NLX	196	75,5	42÷44,5	65	44	12	26		8,5	18	9÷6,5	37	M8	6,6	62	170	320
AD296	230/PL	DS293	230/PLX	196,5	75,5	42÷44,5	66	44	12	26	6		18	9÷6,5		M8	6,6		170	330
AD392	355/NL			270	102	60÷62	100	60	14	41		10,5	22	9,6÷7,5	58	M10	8,6	98	180	730
AD396	355/PL			271	102	60÷62	101	60	14	41	7		22	9,6÷7,5		M10	8,6		180	750
AD492	455/NL			305	120	68÷69,5	113	70	18	41,5		12,5	26	12,5÷11	65	M12	8,7	113	320	1200
AD496	455/PL			306,5	120	68÷69,5	115,5	70	18	41,5	10		26	12,5÷11		M12	8,7		320	1220

HORIZONTAL SERIES WITH ANTI-RELEASE LEVER AND EXTENDED CLAMPING LEVER

Material:

Galvanized steel

Riveted pivots:

Galvanized steel

Supporting bushes:

Hardened and ground steel.

Handles:

Red polyurethane resistant to oils, grease and other chemical agents.

Performance:

Form OLS with extended clamping lever and folded base.

Form PLS with extended clamping lever and straight base.

Spindles:

To be ordered separately (see Accessories on page 87).

Extensions:

The models are supplied with AP6 and AP8 extension as per the drawing and with two flanged washers (see Accessories on page 90).

Features and applications:

The main features of this series are the special anti-release lever and the special extension of the locking arm to facilitate the specific use in control templates; these tools are designed to prevent the operator's fingers from being crushed by the levers when opening. During the closing, the clamping lever is guided laterally to ensure greater stability against possible transverse stresses.

A special grease is placed between two contacting surfaces during assembly.

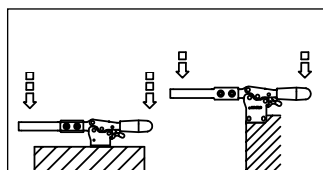

FORM OLS



PATENTED

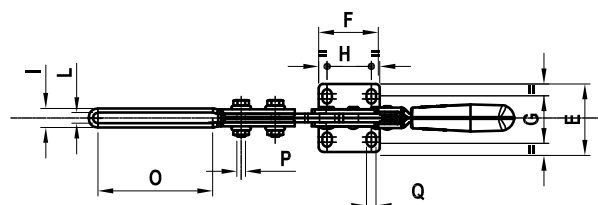
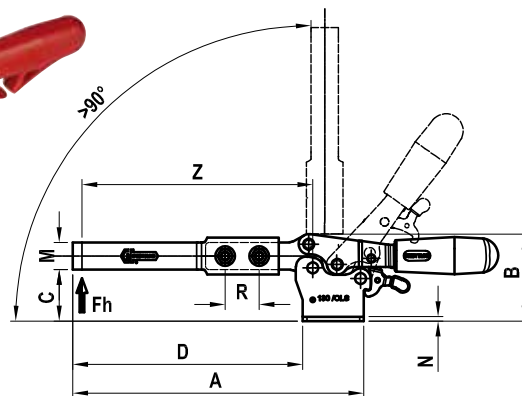

FORM PLS



PATENTED

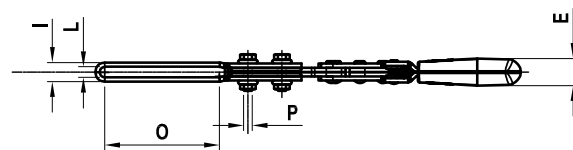
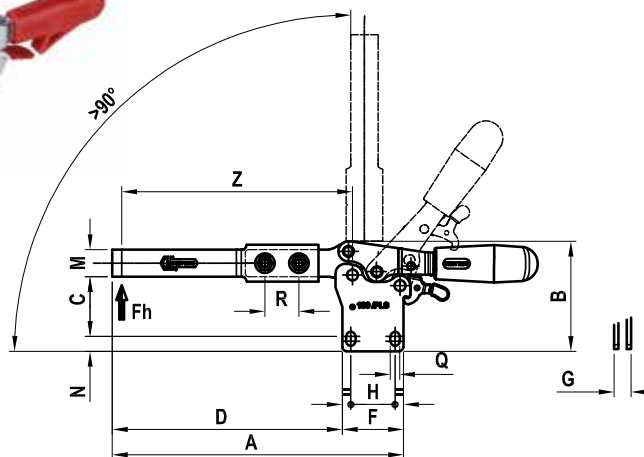

Code	Description	A	B	C	D	E	F	G	H	I	L	M	N	O	P	Q	R	Z	Fh (daN)	gr.
AD146	130/OLS	171	51	30,5	135	40	36	22,4÷28,4	26	11,5	6,3	16	2,5	67,5	M6	5,6	20	134	60	295
AD151	130/PLS	171	64,5	35÷38	135	16	36	10	26	11,5	6,3	16	5,8÷8,8	67,5	M6	5,6	20	134	60	295
AD295	230/OLS	196	61,5	36,5	152	44	44	26÷31,5	26	14,2	8,2	18	3	71,5	M8	6,6	26	150	110	485
AD297	230/PLS	196	75,5	42÷44,5	152	16	44	12	26	14,2	8,2	18	6,5	71,5	M8	6,6	26	150	110	485

FORM MF

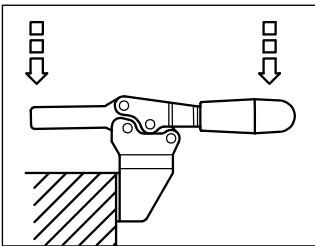
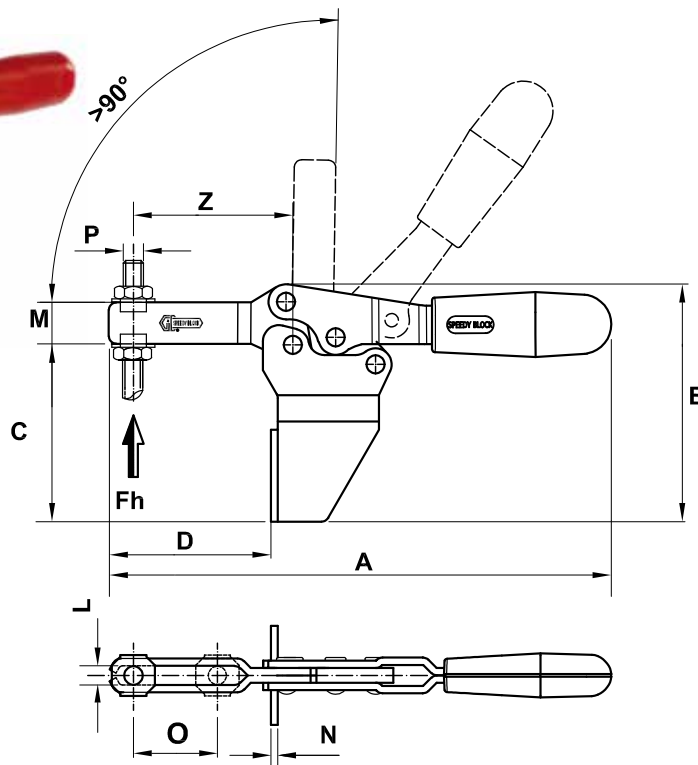

HORIZONTAL SERIES WITH FRONT BASE

Some sizes of this series are also produced in stainless steel and are shown below in red.

Material:

Galvanized steel or **AISI 304 stainless steel**

Riveted pivots:

Galvanized steel or **AISI 304 stainless steel**

Supporting bushes:

Hardened and ground steel (for sizes ≥ 355)

Handles:

Red polyurethane resistant to oils, grease and other chemical agents.

Performance:

Form MF and **form MFX** with open clamping lever and two flanged washers.

Spindles:

To be ordered separately (see Accessories on page 87).

Features and applications:

The main feature of this series is the front mount; these tools are designed to prevent the operator's fingers from being crushed by the levers when opening. During the closing, the clamping lever is guided laterally to ensure greater stability against possible transverse stresses.

A special grease is placed between two contacting surfaces during assembly.

Code	Description	Stainless steel Code	Description	A	B	C	D	E	F	G	H	L	M	N	O	P	Q	Z	Fh (daN)	gr.
AD076	75/MF	DS076	75/MFX	118	62	45	36	30	25,5	18	13,5	5,5	11	2	20	M5	4,5	36	90	105
AD136	130/MF	DS136	130/MFX	171,5	85	64	54	39	35	26	22	6,5	16	2,5	32	M6	5,5	55	100	240
AD271	230/MF	DS271	230/MFX	196	102	77	62	43	40	28,5	24	8,5	18	3	37	M8	6,5	62	170	400
AD371	355/MF			269	135	102	96	52	52	32	32	10,5	22	3,5	58	M10	8,5	98	180	830

