

Adjustable feet

(base in steel)

Part. **96** Ø **113**

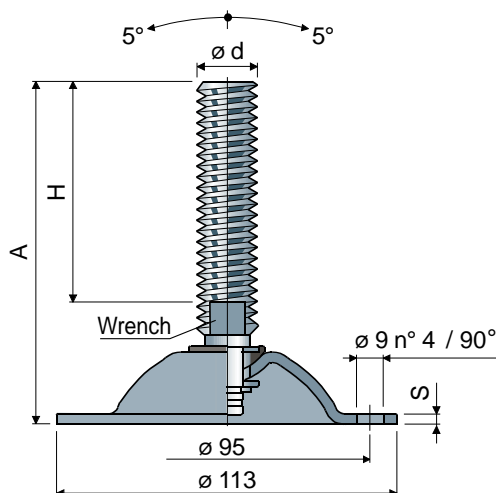

Spindle measures in mm			Spindle and base material			Max static load (N)	
$\varnothing d$	A	H	Wrench	Zinc plated steel Code	Stainless steel AISI 304 Code		
M16x2	100	58	13	96 / 7562	96 / 7563	15000 (zinc plated) S = 3,5	
	161	119	13	96 / 7916	96 / 7917		
	187	145	13	96 / 7564	96 / 7565		
	243	201	13	96 / 7566	96 / 7567		
M18x2,5	199	157	15	96 / 82138	96 / 82139		10000 (AISI 304) S = 3
	134	89	17	96 / 87322 NEW	96 / 87323 NEW		
	152	107	17	96 / 7568	96 / 7569		
M20x2,5	181	136	17	96 / 7570	96 / 7571		
	202	157	17	96 / 7572	96 / 7573		
	235	190	17	96 / 83232	96 / 83233		
	283	238	17	96 / 83234	96 / 83235		
M24x3	138	90	19	96 / 7574	96 / 7575		
	175	127	19	96 / 7576	96 / 7577		
	210	162	19	96 / 7578	96 / 7579		
	250	202	19	96 / 83236	96 / 83237		
M30x3,5	173	125	24	96 / 7580	96 / 7581		
	233	185	24	96 / 7582	96 / 7583		

Box quantity: 8 pieces.

Washers UNI 6592-69 - Box quantity: 24 pieces.

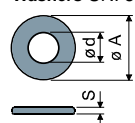

$\varnothing M$	M16	M20	M24	M30
Smm	3	3	4	4
$\varnothing A$ mm	30	37	44	56
Zinc plated steel codes	7289	7290	7293	7295
Stainless steel codes	7291	7292	7294	7296

Nuts UNI 5588-65 - Box quantity: 24 pieces.

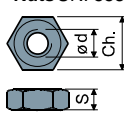

$\varnothing d$	M16	M20	M24	M30
Smm	13	16	19	24
Ch. mm	24	30	36	46
Zinc plated steel codes	7275	7276	7279	7281
Stainless steel codes	7277	7278	7280	7282

On request

- Spindles with: Sunk hexagon head • second wrench seat head • hexagon wrench seat • threads with other pitches and lengths • stainless steel AISI 316.
- Box quantity: Not standard.
- Assembling of: Nuts • washers.